



Performance of Beam Incorporating with Locally Available Reinforcement

Mir Abdul Kuddus^{1*}, Md. Naimul Islam Mohim²

¹Assistant Professor, Department Of Civil Engineering, Khulna University Of Engineering & Technology, Khulna-9203, Bangladesh,

²Student, Department Of Civil Engineering, Khulna University Of Engineering & Technology, Khulna-9203, Bangladesh

Received 07 Jan, 2017; Accepted 31 Jan, 2017 © The author(s) 2017. Published with open access at www.questjournals.org

ABSTRACT : This study comparatively evaluated the flexural performance and deformation characteristics of concrete beams reinforced with bamboo, cane and the twisted steel rebar. The yield strength (YS), ultimate tensile strength (UTS) and the elongation of nine specimens of the three materials were determined using a universal testing machine. Nine beams of concrete strength 22 MPa at age 28 days were constructed separately reinforced with steel, bamboo, and cane bars, while the stirrups were steel bars. The beams were subjected to centre-point flexural loading according to ASTM C0293 to evaluate the flexural strength. The tensile strength of bamboo and rattan bars was 43% and 13% of that of steel in the same order. The elongation of bamboo, rattan and steel were 11.5%, 14% and 15.7% respectively. The experimental flexural strength of bamboo and cane reinforced concrete beams was 34% and 26% respectively of the conventional steel RC beams. The remarkable gap between the flexural capacities of the natural rebar and that of steel can be traced not only to the tensile strength but also the weak bonding at the bar-concrete interface. It can be concluded that the bamboo bars are suitable rebar for non-load bearing and lightweight RC flexural structures, while more pre-strengthening treatment is required more importantly for rattan for improved interfacial bonding and load-carrying capacity.

Keywords: Reinforcing Bars, Bamboo, Cane, Tensile Characteristics, Flexural Strength, Load-Carrying Capacity

I. INTRODUCTION

The overall sustainable economic growth, productivity, and the well-being of a nation depend heavily on the functionality, reliability, and durability of its constructed facilities. However, aside the environmental and operational condition, the constituent materials accounting for the increasing cases of structural deficiency and functional obsolescence are recorded in the built environment [1]. Reinforced concrete (RC) structures account for majority of the constructed facilities globally and their performance is greatly influenced by the properties of the reinforcing bars. The transfer of stress from concrete to steel is made possible through effective bond between concrete and the reinforcement. Previous studies on the chemical, physical and strength characteristics of steel reinforcing materials revealed the dangers of maximizing profit at the expense of quality, a situation that pose a major challenge to the structural reliability and durability of buildings and civil infrastructure [2]. Although extensive studies have been carried out on synthetic and natural non-ferrous reinforcing materials in the past decades, natural reinforcement still remains a dynamic field of further investigation. Numerous studies have been carried out on natural reinforcing materials such as wood [3], jute [4], bamboo [5], palm stalk [6] and raffia palm [7]. Attention is gradually been focused on the use of bamboo (*Bambusa vulgaris*), rattan (*Calamus deerratus*) and other natural fiber reinforcing materials as alternative reinforcements in concrete especially for low-cost housing for rural communities.

Research findings indicate that the strength of bamboo increases with age. The optimum strength value occurs between 2.5 and 4 years. The strength decreases at a later age [8]. One of the amazing aspects of bamboo is the way it interacts with the environment. It has been discovered that bamboo can prevent pollution by absorbing large amounts of nitrogen from waste water and reducing the amount of carbon dioxide in the air [9]. Many researchers have tried to use bamboo as substitute of steel in reinforced concrete. [10] and [11] have reported its use in construction of water tanks. [12] Reported its use as reinforcement for lightweight concrete

*Corresponding Author: Mir Abdul Kuddus¹
Department Of Civil Engineering, Khulna University Of Engineering & Technology,
Khulna-9203, Bangladesh

beams. [13] and [14] developed bamboo-based ferrocement slab elements for roofing/flooring purpose in low cost housing. [15] Studied its applications in RC slabs. The maximum tensile strength of 133.54 N/mm² for bamboo as opposed to 204- 250 N/mm² obtained by [16]. Further investigation showed that bamboo RC beams had 134.65% of the load-carrying capacity of the unreinforced beams at 28- day. The load capacity of mild steel RC beams was 1.5 times that of its equivalent bamboo RC beams [17].

The experiment was with tohiti rattan that has stronger and higher power after preservation [18]. [19] Investigated the properties of rattan cane reinforced concrete facade, and observed that rattan cane reinforced facade and the conventional steel reinforced facade both experienced flexural type of failure. However due to the low modulus of elasticity of rattan cane, its facade exhibited larger strain than those of steel reinforced facade. The experiment further showed that rattan facade has lower crack widths when compared with that of steel which gave it advantage when exposed to moisture.

1. Methodology and experimental program

The experimental program of this research is designed for two kind of tests; tensile testing of steel, bamboo and cane and flexural strength test by center point loading of steel, bamboo and cane reinforced concrete beam. To determine the tensile strength properties of steel, bamboo, cane and flexural strength of steel, bamboo, cane reinforced beam some methods should be followed and these are given below.

1.1. Material Characterization

Stone chips which are of 19 mm downgrade size were used as coarse aggregate. Specific gravity, absorption and unit weight were determined according to ASTM testing standards respectively. Specific gravity, absorption and unit weight of stone chips were found 2.71, 0.9% and 1570 kg/m³ respectively. Sylhet sand was used as fine aggregate. Different properties such as specific gravity, absorption, and fineness modulus and unit weight were determined according to ASTM testing standards respectively. Specific gravity, absorption, fineness modulus and unit weight of coarse sand were found 2.41, 4.85%, 2.92 and 1621 kg/m³ respectively. Portland cement was used as binder. Portland Cement Composite was used as binder material. Properties as normal consistency, initial setting time, final setting time of Portland cement composite (PCC) were determined according to ASTM testing standards respectively. Normal consistency, initial setting time and final setting time of Portland cement were found 28.5%, 145 minute and 270 minute respectively.

2.2. Compressive strength test of concrete specimen

The compressive strength was determined by using compressive strength testing machine. The specimens were placed vertically in the instrument one by one and tested. Then the compressive strength was determined using equation (1). Compressive strength of concrete after 28 days was found 21.5 MPa using cylinder of diameter 100 mm and height 200 mm.

$$C = \frac{P}{A} \quad (1)$$

Where, C = compressive strength; P = failure load; A = contact area.

2.3 Tensile properties of the steel, bamboo and rattan (cane) bar

All the specimens were cut to standard length 600 mm and gauge length 200 mm and the diameter of the specimens are about 10mm. The tensile strength properties of steel, bamboo and rattan were determined experimentally by universal testing machine (UTM) as shown in Fig.1. In order to conduct the tensile tests, it was necessary to prepare the steel, bamboo and cane samples. The samples were cut to proper size and shape. All the specimens were cut to standard length 600 mm and gauge length 200 mm. The diameter of the steel bars was 10mm. The diameter, along the length, differed between the samples because bamboo and rattan are natural material whose physical properties vary. For this reason a careful dimensioning of the sample was done before testing the bamboo. About 3-year old greenish –brown bamboo of 6.0 m height of the same species sourced from Khulna were sliced into 10 mm bars. The average internodes distance of bamboo was 250-400 mm, external diameter of the trunk was 85-105 mm, and the thickness was 10-15 mm. Rattans were sourced from Khulna and cut into several lengths of 10 mm diameter. Rattan stems cut and air dried for one month prior to cutting to standard lengths. The five points included the midpoint, the ends and two points approximately halfway between the middle and the ends. The distance between nodes were also measured and recorded. Measuring the dimensions of the specimens made it possible to determine the average stresses and strains in each sample.



Figure 1. Test setup for tensile test of cane specimen

2.4. Preparation of beam specimen

2.4.1. Beam design

Concrete was poured in molds of 150 mm width, 150 mm depth and 750 mm length, along with 3 types of reinforcement bars separately (steel, bamboo and cane). Three types of beams were constructed namely steel reinforced beam, bamboo reinforced beam and cane reinforced beam while the stirrups were same steel bars. Fig.2 shows the dimensions of sample beams

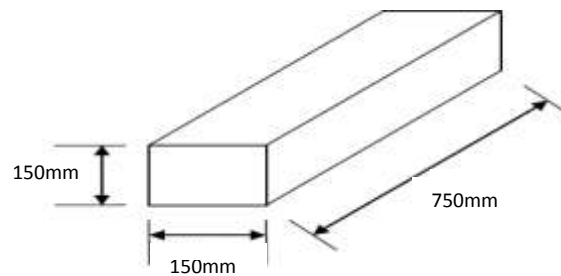

Figure 2. Dimensions of beam specimen.

Reinforcement preparation

Reinforcement preparation for beam construction is same as like as bars for tensile test. Bamboo and rattan bars are length of 700 mm and steel bars are length of 750 mm. The diameter of the reinforcement bars was provided 10 mm. The diameter of 6 mm share reinforcement was also provided. Fig.3 shows the different types of reinforcement.



Figure 3. Cane (a) and bamboo (b) reinforcement with steel stirrups.

2.4.5. Formwork preparation

Formwork was prepared to support the freshly placed concrete and the reinforcement bars of the beam. Ready metal formwork which dimension is 750 mm long, 150 mm height and 150 mm width was used which is shown in Fig.4. The oil was provided inner side of the formwork so that concrete cannot bond with metal.



Figure 4. Formwork preparation for beam specimen.

2.5. Test setup

Three replicas of the beam specimens were reinforced with bamboo, rattan and steel longitudinal bars and denoted as bamboo RC beams (BB), rattan RC beams (RB) and steel RC beams (SB). The longitudinal bars of diameter 10 mm were sliced from rattan and bamboo, while reinforcing steel bars were also of 10 mm size. Mild steel of 6 mm diameter were employed as stirrups to resist shear for the three RC beam types. The beam was placed carefully to provide the supports at the measured placement of 3 in from each end. The beam was then placed under the testing machine. A dial gauge was also provided for measuring the deflection of the beam. After placing the beam, one point load at the middle of the beam was applied gradually by universal testing machine. The Fig.5 shows the testing of beam for point loading and Fig.6 represents the schematic view of the test specimen.



Figure 5. Test setup for one point loading test.

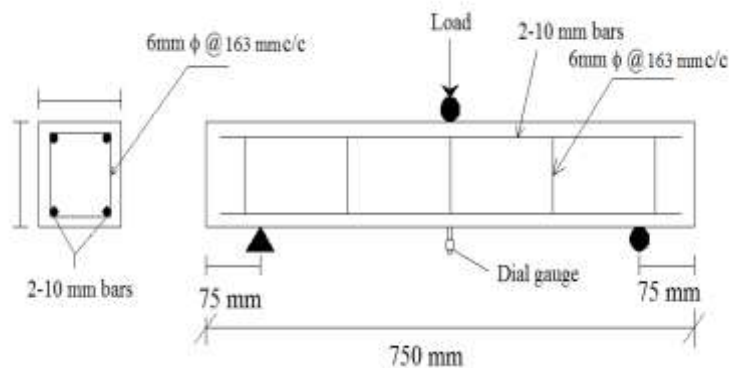

Figure 6. Schematic diagram of flexural test setup of RC beam with geometric and reinforcement details.

Test results

The results of beam test conducted with steel, bamboo and cane reinforced concrete beams is given in the Table 1. Tensile samples (bamboo and cane) varied the presence of nodes to investigate their effect on bamboo and cane strength.

Table 1. Flexural strength of steel, bamboo and cane reinforced beam.

Specimen	Ultimate Load (KN)	Flexural Strength (MPa)
Steel Reinforced Beam	53.7	14.32
Bamboo Reinforced Beam	18.3	4.88
Cane Reinforced Beam	14	3.73

In addition, the experimental ultimate failure loads of bamboo and rattan RC beams were 34% and 26% respectively of the conventional steel RC beams. This indicates that the carrying capacity of bamboo RC beams is about bellow one-half of the conventional steel RC beams, while rattan RC beams were barely one-quarter of the steel RC beams capacities. The flexural strengths of bamboo, rattan and steel RC beams were 4.88, 3.73 and 14.32 MPa were shown in Table 1. The indication of this is that the flexural strengths of bamboo and rattan RC beams were 34% and 26% respectively of the conventional steel RC beams.

For clear comparative evaluation of the flexural behaviour of steel, bamboo and cane reinforced beams, the mean load-deflection curves of beam samples reinforced with each of the reinforcing materials are shown in Fig.7. Ultimate load was found 60 KN and maximum deflection was found 5.36 mm for steel reinforced beam.

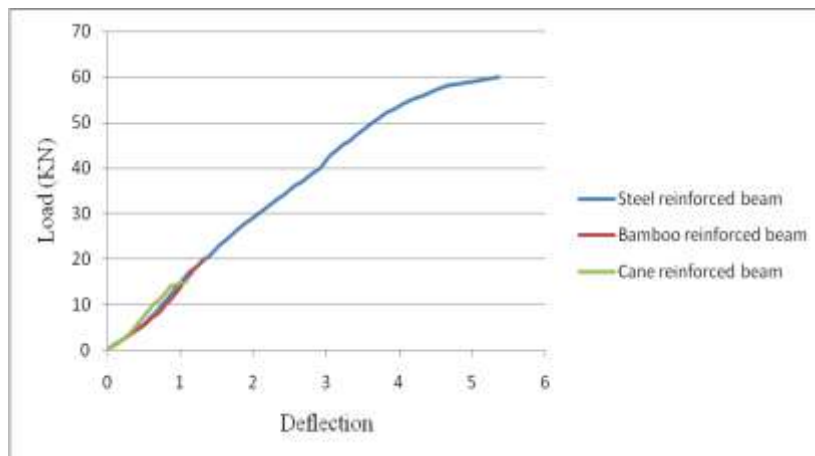

Figure 7. Load-deflection curve of steel, bamboo and cane reinforced beam.

3.1 Failure pattern of test specimens

Figure 8 shows the mode of failure for steel RC beams was shear, indicated by diagonal cracks because of the short-span specimen adopted and the relatively higher tensile strength than the bamboo and rattan RC beams which failed by flexure.

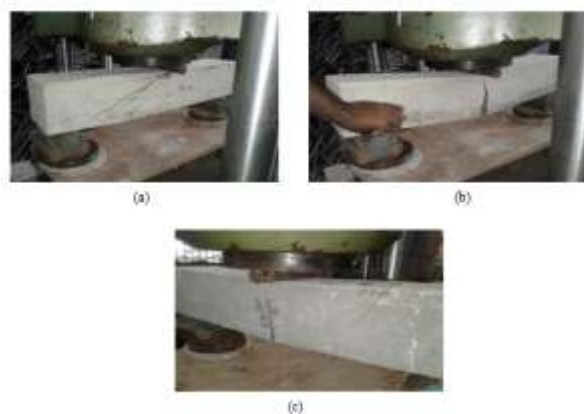

Figure 8. Failure pattern of steel (a), bamboo (b) and cane (c) reinforced beam.

II. Conclusion

The following salient conclusions can be drawn from the study.

- The tensile strength of cane and bamboo represented 12% and 43% of that of steel reinforcing bars. The elongation of bamboo and rattan meet the ductility requirements of 12%. The elongation of bamboo, cane and steel were 11.5%, 14% and 15.7% respectively.
- The flexural strength of bamboo and rattan reinforced concrete beams was 34% and 26% respectively of the conventional steel RC beams.
- The mode of failure for steel RC beams was shear, indicated by diagonal cracks because of the short-span specimen adopted and the relatively higher tensile strength than the bamboo and cane RC beams which failed by flexure.
- The flexural and bonding strengths of bamboo and cane RC beams could be enhanced by bonding galvanized iron or fibre thread spirally round the surface of the bars with epoxy.

REFERENCES

- [1]. Adewuyi, A.P., Wu, Z.S. and Raheem, A.A. (2010) Adaptation of Vibration-Based SHM for Condition Assessment and Damage Detection of Civil Infrastructure Systems. LAUTECH Journal of Engineering & Technology, 6, 1-11.
- [2]. Basu, P.C., Shylamoni P. and Roshan A.D. (2004) Characterization of Steel Reinforcement for RC Structures: An Overview and Related Issues. Indian Concrete Journal, 78, 19-30.
- [3]. Andonian, P., Mai, Y.M. and Cotterell, B. (1979) Strength and Fracture Properties of Cellulose Fibre Reinforced Cement Composites. International Journal of Cement Composite Lightweight Concrete, 1, 151-158
- [4]. Manzur, M.A. and Aziz, M.A. (1982) A Study of Jute Fibre Reinforced Cement Composites. International Journal of Cement Composite Lightweight Concrete, 4, 75-82.
- [5]. Kankam, J.A., Ben-George, M. and Perry, S.H. (1988) Bamboo-Reinforced Beams Subjected to Third-Point Loading. ACI Structural Journal, 85, 61-67.
- [6]. Kankam, C.K. (1994) The Influence Of Palm Stalk Fibre Reinforcement on the Shrinkage Stresses in Concrete. Journal of Ferrocement, 24, 3-12.
- [7]. Kankam, C.K. (1997) Raffia Palm-Reinforced Concrete Beams. Materials and Structures, 30, 313-316.
- [8]. Amada, S. and Untao, S. (2001), "Fracture Properties of Bamboo", Composites Part B, Vol. 32, pp 451-459.
- [9]. Steinfeld, C (2001), "A Bamboo Future", Environmental Design and Construction, pp 1-5.
- [10]. Winarto, Y.T. (1989) Rainwater Collection Tanks Constructed on Self Help Basis. Journal of Ferrocement, 19, 247-254.
- [11]. Chembi, A. and Nimityongskul, P. (1989) A Bamboo Reinforced Cement Water Tank. Journal of Ferrocement, 19, 1-17.
- [12]. Ghavami, K. (2004), "Bamboo as Reinforcement in Structural Concrete Elements", Cement & Concrete Composites.
- [13]. Venkateshwarlu, D. and Raj, V. (1989) Development of Bamboo Based Ferrocement Roofing Elements for Low Cost Housing. Journal of Ferrocement, 19, 331-337.
- [14]. Raj, V. (1990) Large Span Bamboo Ferrocement Elements for Flooring and Roofing Purposes. Journal of Ferrocement, 20, 367-375.
- [15]. Kankam, J.A., Ben-George, M. and Perry, S.H. (1988) Bamboo-Reinforced Beams Subjected to Third-Point Loading. ACI Structural Journal, 85, 61-67.
- [16]. Falade, F.A. and Akeju, T.A.I. (2002) Structural Design and Economy of Bamboo Reinforced Concrete Beams. Proceedings of the Fifth International Conference on Structural Engineering Analysis and Modelling, Accra, 26-28 February 2002, 215-228.
- [17]. Akeju, T.A.I. and Falade, F.A. (2001) Utilization of Bamboo as Reinforcement in Concrete for Low-Cost Housing. Proceedings of the International Conference on Structural Engineering, Mechanics and Computation, Cape Town, 2-4 April 2001, 1463-1470.
- [18]. Nurul A. Rattan and its Direct Benefits. www.rattan-wicker-globent.com; (2011). Accessed Nov. (2011).
- [19]. Alade, G.A., Olutoge, F.A. and Alade, A.A. (2004) The Durability and Mechanical Strength Properties of Bamboo in Reinforced Concrete. Journal of Applied Science, Engineering and Technology, 1, 35-40.