

Research Paper

# Performance of FRP Composite Panels in Architectural Applications

Hend ElZefzafy

Assistant Professor, College of Engineering, Applied Science University (ASU), Bahrain, In Partnership with London South Bank University, London, United Kingdom

## ABSTRACT

The durability of fiber-reinforced polymer (FRP) composite material have attracted the engineers to be used as replacement to architectural construction materials. FRP materials are noncorrosive, lightweight, exhibit high tensile strength, and stiffness, are easily fabricated and constructed. For architectural applications, FRP materials are fabricated using a polymer matrix, such as epoxy, vinylester, or polyester, and reinforced with various grades of carbon, glass, and/or aramid fibers. In this paper, a review on using the FRP as cladding/panel architectural construction materials have been introduced, discussed and presented. Details of the advantages of FRP composite panel have been presented. Since glass FRP (GFRP) materials is more economical than the available types (carbon and aramid) of FRP, it is more attractive for architectural applications and to the construction industry. A review on GFRP panels for exterior architectural applications for three worldwide real projects have been discussed. The construction procedure and field application under actual service conditions revealed that FRP panels provides very good and promising performance.

**KEYWORDS:** Fiber-reinforced polymer; Panels, Architectural; Application, Sustainable; Durable.

Received 28 Nov, 2021; Revised 10 Dec, 2021; Accepted 12 Dec, 2021 © The author(s) 2021.

Published with open access at [www.questjournals.org](http://www.questjournals.org)

## I. Introduction

Fiber-reinforced polymer (FRP), also fiber-reinforced plastic, is a composite material made of a polymer matrix reinforced with fibers, see Figure 1. The fibers are usually glass, carbon, or aramid, although other fibers such as paper or wood or asbestos have been sometimes used. The polymer is usually an epoxy, vinylester or polyester thermosetting plastic, and phenol formaldehyde resins are still in use. FRPs are commonly used in the aerospace, automotive, marine, and construction industries[1].

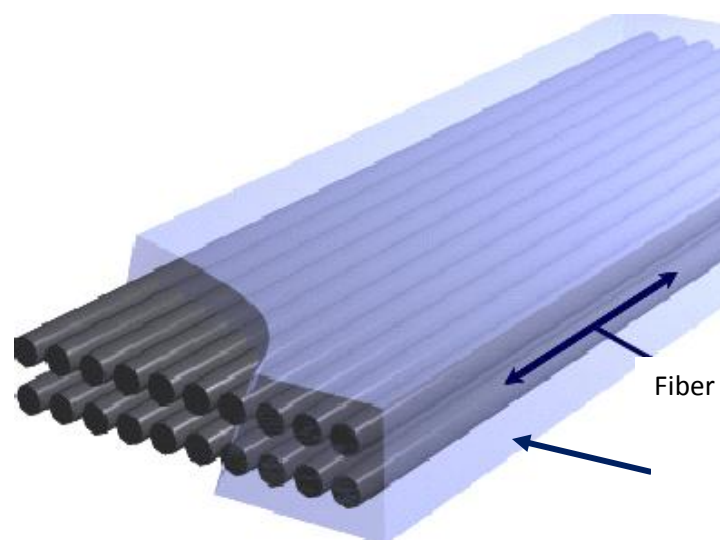

Figure 1. FRP composite materials

This advancement further brought about a dynamic change in the building industry, by therefore producing innovative and sustainable FRP materials provide unique properties as well as wide variety of functions, and structural performance qualities that are durable, sustainable and environmentally friendly [2]. These materials offer a new aesthetic possibilities and ability to mould complex fluid and create design of different forms, shapes and styles[3]. Saving time in construction and installation and cost on site. It can have special integrated surface finishes and effects. Being able to offer valuable savings in weight usually up to 15%. In addition, it can offer stronger durability with degradation through service life. FRP materials provide the different possibilities of architectural design. Temperature and chemical properties can be design to fit different environment. FRP materials provide flex performance and dimensional stability.

### **FRP Panels as Innovative Architectural Materials**

Unitized panel systems have become a popular alternative to conventional, stick-built construction in building envelopes. Prefabricated offsite, under controlled factory conditions, these systems vastly simplify onsite installation, decreasing expensive jobsite labor and shortening construction schedules. In 2009, the International Code Council's (ICC, Washington, D.C.) International Building Code (IBC) approved the use of fiber-reinforced polymer (FRP) composites in unitized panels[4].

FRP panels have several advantages over the conventional architectural materials, see Figure 2. FRP panels is a low-cost, easy-to-install system that turns drywall or other surfaces into valuable wall. It is a scratch-resistant material, and it can be washed and cleaned easily using regular detergents, high-pressure washers, or even steam[5]. Compared to conventional architectural materials, it is lighter, more flexible and easy to install. The FRP panel can be installed with glue or fasteners, or both. In addition, it has maximum sanitation protection with higher Improved chemical resistance and durability. It can be considered on any different materials using basic and techniques. Moreover, the FRP materials have high impact resistance from shattering and scratches. Cost effective over other conventional architectural materials. FRP panel are noncorrosive materials, help prevent the growth of mold, and higher strength to weight ratio.

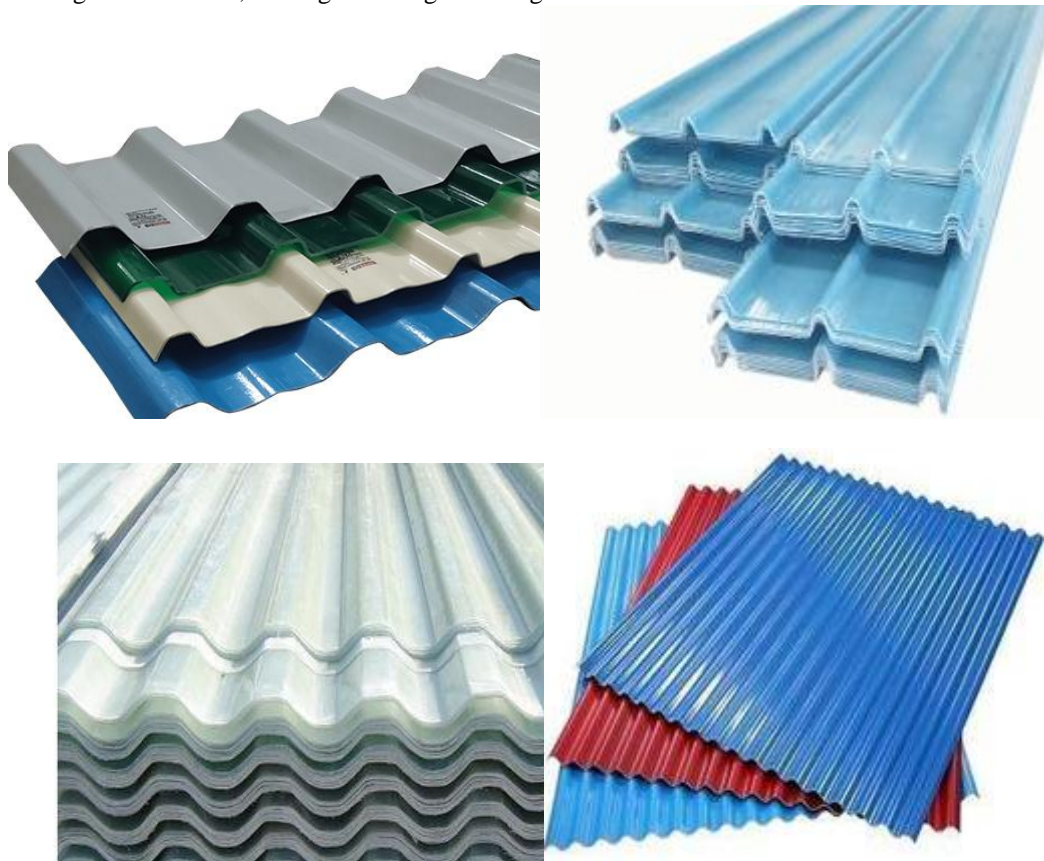

Figure 2. FRP Panels: Different manufacturing products

All of these advantages make FRP panels as the best choice and an excellent material for covering walls and ceilings in restaurant kitchens, public bathrooms, medical facilities, food processing areas, and many other environments requiring frequent deep-cleaning. FRP panel system is durable and thin. It is made of high strength resin reinforced with glass fiber. They are used on walls and ceilings and can be installed directly over

drywall, wood, concrete block, and many other solid surfaces. FRP systems include plastic trim molding to create a continuous durable, scratch-resistant surface that is easy to clean and mold- and stain-resistant. The panels can even be hosed down for cleaning. FRP wall panels are ideal for kitchens, restrooms, dining rooms, offices, classrooms, hospital rooms, hallways, cooling towers, recreational areas, and other secondary spaces. One of the most important applications of FRP panels is that they can be installed over new and existing drywall or used to repair damaged surfaces[6].

## **FRP Panels in Architectural Applications**

### **Museum of the Future**

In an area known for driving the limits of architectural design, the Dubai Future Museum is one of the most complex projects to date, adding a unique new dimension to the skyline of downtown Dubai. The Museum of the Future symbolizes both future progress and the regional design influence of Dubai with its use of durable, sustainable and innovative materials. Parametric design was used to develop the steel diagrid — a framework of 2,400 diagonally intersecting steel members — to which composite concrete floor slabs and 17,000 square meters of composite cladding are attached, the latter using 1 million square meters of multiaxial glass and carbon fiber-reinforced epoxy prepreg[4]. Specialist engineers developed bespoke in-house optimization routines to model and analyses numerous options for the structure to achieve the Museum of the Future’s iconic shape. External buildings’ panels surfaces in UAE can reach temperatures of 80°C in summer, the prepreg was cured at 120°C to ensure sufficient T<sub>g</sub> (glass transition temperature) to resist head deformation and deflection. Thus, the molds were machined out of a polyurethane foam which could withstand that high temperature, which is more expensive Figure 3. Three or four different foams have been tested but only one could withstand the temperature plus vacuum pressure, and yet was soft enough to CNC machine easily and quickly. The outcome was a solution comprised of a complex diagrid framework directly aligned to torus shape and capable of supporting the 890 stainless steel and glass fiber reinforced polymer (GFRP) 3D composite panels that form the intricate silvery façade [7]. The exterior facade of the torus comprises 1,024 fire-retardant (FR) composite panels. They also serve as the building’s windows, casting daylight through the column-free interior and creating a dramatic effect at night via 14 kilometers of integrated LED lighting. Dubai firm Affan Innovative Structures provided the composite design for the panels, as well as fabrication and support for installation. The first-time composite panels have been used to integrate multiple building functions via such complex shapes[4]. This unique project combines lightweight carbon fiber and fiberglass prepreps, and its fire performance has been recognized by the Dubai Civil Defence Department.

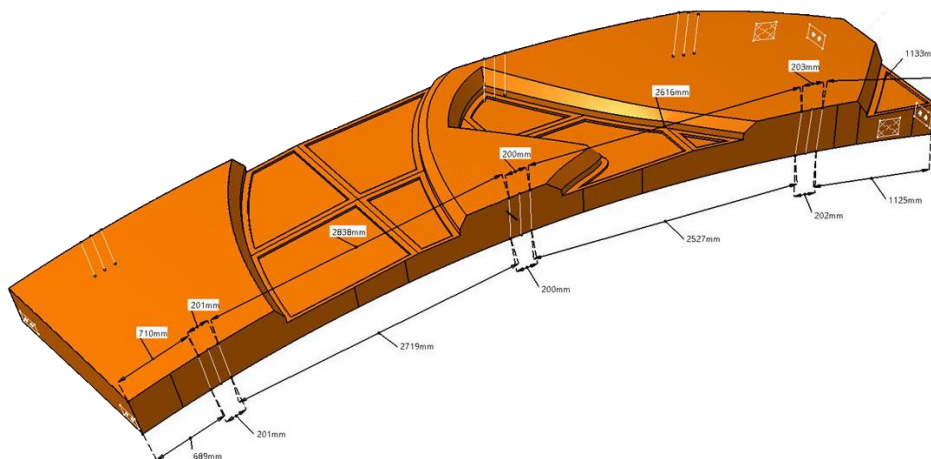

Each complex-curved facade panel was designed in CATIA to include Arabic script cutouts and varying recesses for flat glass windows, as well as “cassette” edges reinforced to support lifting during installation and attachment to the building’s steel framework. These were then translated into designs for molds CNC machined from PU foam. Source | Affan Innovative Structures





Figure 3. Stainless-steel-clad glass fibre reinforced plastic (GFRP) form the building's landmark facade.

#### **Architectural FRP Cladding in San Francisco Museum of Modern Art**

The San Francisco Museum of Modern Art (SFMOMA) is a modern and contemporary art museum located in San Francisco, California, see Figure 4. A nonprofit organization, SFMOMA holds an internationally recognized collection of modern and contemporary art, and was the first museum on the West Coast devoted solely to 20th-century art. The museum's current collection includes over 33,000 works of painting, sculpture, photography, architecture, design, and media arts, and moving into the 21st century. The collection is displayed in 170,000 square feet (16,000 m<sup>2</sup>) of exhibition space, making the museum one of the largest in the United States overall, and one of the largest in the world for modern and contemporary art. The San Francisco Museum of Modern Arts underwent major expansion and renovation, and reopened its doors in 2016[8]. The expansion more than doubles the museum's gallery spaces and provides almost six times as much public space as the previous building, allowing SFMOMA to showcase an expanded collection along with the Doris and Donald Fisher Collection of contemporary art.



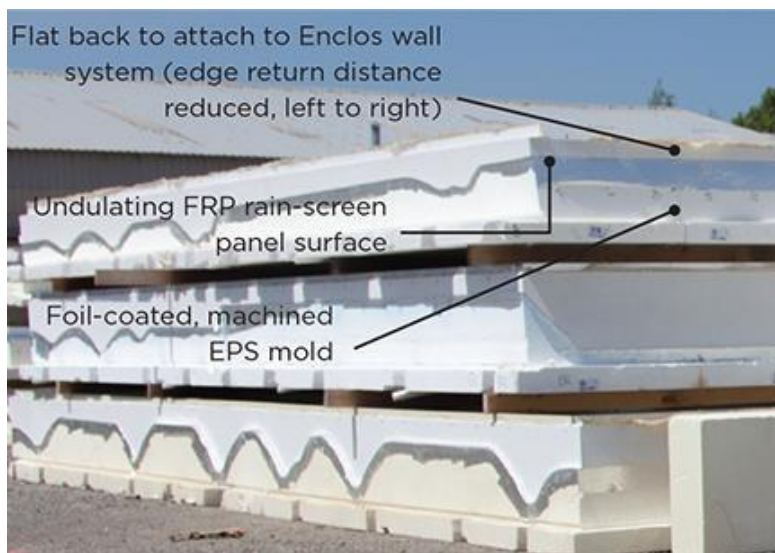

Figure 4. Cladding made from FRP composites

This renovated building featuring a 10-story rippled, undulated, and curved facade, is the largest architectural application of FRP composites in the US[8]. It is, to date, the largest architectural use of fiber-reinforced plastic (FRP) in a US building project — more than 700 panels, some as large as 1.5m wide by 9m long, totaling 7804m<sup>2</sup> on a contoured 10-story façade[4]. Some of the individual FRP panels measure 5.5 ft wide by 30 ft in length, while the skin thickness is only 3/16 in. The FRP composites were mechanically fastened and bonded using customized aluminum extrusion. It is the first time a composite system has passed the rigorous fire-regulation testing that permits its use above the fourth story on a high-rise exterior in the US. The FRP composite system successfully passed the National Fire Protection Association (NFPA) 285 fire testing for use on high-rise building applications. There were many reasons why FRP was chosen in this particular project including its durability, very high strength-to-weight ratio compared to steel, overall shorter schedule for construction completion, and inherent form shaping capability into complex shapes as shown in Figure 4. The FRP composites ability to offer significant energy savings when used as a thermal bridging between the exterior and the interior of a building is also praised by the architectural and engineering community. This project's success is considered a monumental step for the use of FRP composite in future cladding designs that strive to stay ahead of the traditional curtain wall systems[8].

### **Chanel Pavilion**

This travelling pavilion was designed, for Chanel, by ZahaHadid and has been first exhibited in Hong Kong, Tokyo, to celebrate the iconic Chanel handbag[9]. The architectural structure of the Pavilion is a series of continuous arch-shaped elements, with a courtyard in its central space. The glazed ceiling adjusts to allow for control of the interior temperature in response to the particular climate conditions of each venue city[10]. The entire building is designed to be transported by sea around the world. The structure and contents fit into standard shipping containers, using as little material as possible. On arrival, the pavilion can be assembled in three weeks. When it is time to move on, the structure can be dismantled within a similar period. From there it was packed up in 55 sea containers and shipped to Tokyo, closing there and heading to New York. Figure 5 shows it in New York's Central Park. Exhibiting Chanel's quilted bags designed by Karl Lagerfeld. FRP was selected for its formability (using hundreds of molded fiberglass panels mounted on a skeletal steel frame), lustrous finish and above all lightness as the pavilion needed to be transported between venues (Stacey 2008). The dichotomy between the powerful sculptural mass of the Chanel Pavilion's structure and the lightness of its envelope create a bold and enigmatic element. The Pavilion's exterior develops into a rich variety of interior spaces that maximize the potential to reuse and rethink space due to the innate flexibility of its plan[10].

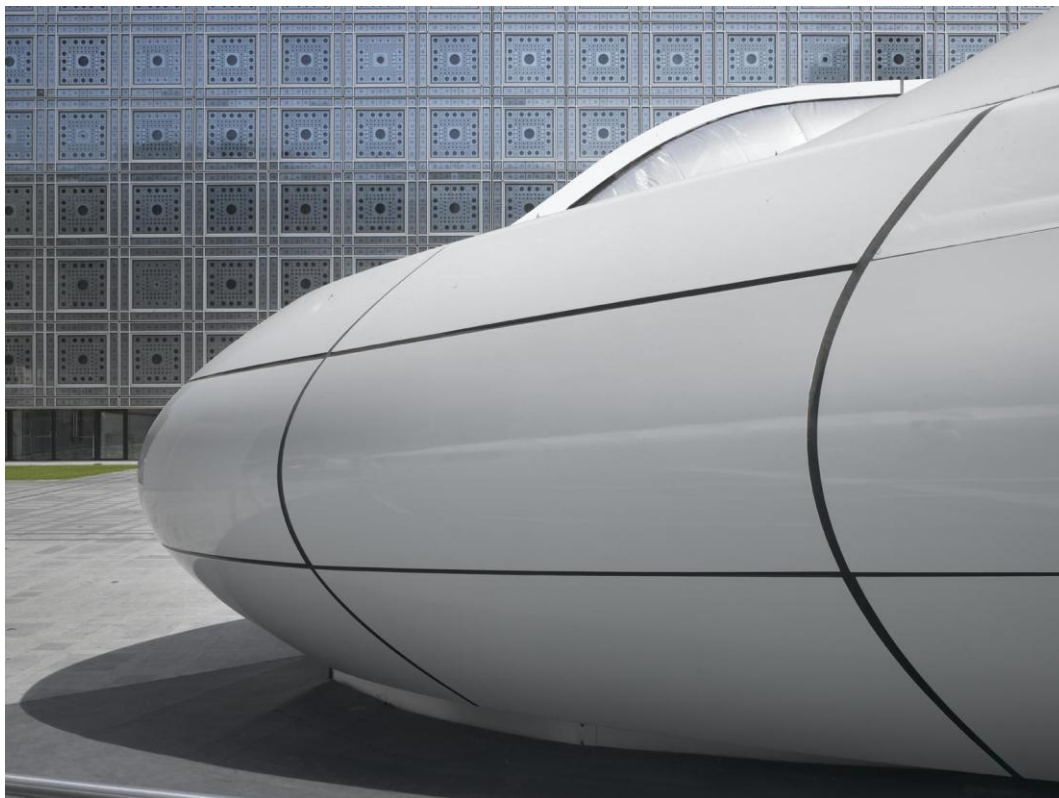

Figure 5. The Chanel Pavilion in Central Park

## II. CONCLUSIONS

The durability of fiber-reinforced polymer (FRP) composite material have attracted the engineers to be used as replacement to architectural construction materials. In this paper, a review on using the FRP as cladding/panel architectural construction materials have been introduced, discussed and presented. A review on GFRP panels for exterior architectural applications for three worldwide real projects have been discussed. The construction procedure and field application under actual service conditions revealed that FRP panels provides very good and promising performance. The FRP panels withstood normal on site handling and placement with no problems. In addition, their light weight made them easy to carry and easier to place. The applications of FRP panels involving building of different types and subjected to a variety of environments and service conditions contribute significantly to establishing a data base of these materials for more applications.

## REFERENCES

- [1]. Guo, Z., Li, Z., Liu, J., Chen, M., Zu, Q., Zhang, Y., ... & Chen, J. (2014). Ex-situ method for toughening glass/epoxy composites by interlaminar films made of polyetherketone cardo and calcium sulfate whisker. *Journal of Reinforced Plastics and Composites*, 33(21), 1966-1975.
- [2]. Akadiri, P. O., Chinyio, E. A., & Olomolaiye, P. O. (2012). Design of a sustainable building: A conceptual framework for implementing sustainability in the building sector. *Buildings*, 2(2), 126-152.
- [3]. Adeola, O. O., & Alfa, M. T. (2018). The Role of Advance Composite material In Contemporary Buildings. *Journal of Contemporary Urban Affairs*, 2(3), 95-101.
- [4]. <https://www.compositesworld.com/articles/building-the-museum-of-the-future>
- [5]. Rajamanickam, U., Singhal, A., & Jothi, M. (2015). *FRP mold and panel manufacturing for FSAE body panel and driver seat* (No. 2015-01-0727). SAE Technical Paper.
- [6]. JUAN RODRIGUEZ, (2018) How to Use Fiberglass Reinforced Panels (FRP), The Advantages of Flexible FRP, (<https://www.thebalancesmb.com/>)
- [7]. Projects to Look Out For In 2020 (Part 2) | BuroHappold Engineering “<https://igsmag.com/features/architecture/projects-to-look-out-for-in-2020-part-2-burohappold-engineering/?cv=1>”
- [8]. [https://krishisanskriti.org/vol\\_image/04Nov201806115609%20%20%20%20%20%20%20%20%20Radhika%20Pathak%20%20%20%20%20%20533-537.pdf?cv=1](https://krishisanskriti.org/vol_image/04Nov201806115609%20%20%20%20%20%20%20%20%20Radhika%20Pathak%20%20%20%20%20%20533-537.pdf?cv=1)
- [9]. <https://compositesuk.co.uk/LinkClick.aspx?cv=1&fileticket=51z23k8jRTU%3D&tabid=103&mid=526&forcedownload=true>
- [10]. CHANEL's New Pavilion in Venice by ZahaHadid <http://dailyupdateinteriorhousedesign.blogspot.com>.