

Optimizing the Indirect Tensile Strength of Acidified-Conventionally Modified Lateritic Soils

^{1*} Eme Dennis Budu, ²Sogules Charles Korubo, ³Ohwerhi Kelly Erhiferhi

^{1,2,3}Department of Civil and Environmental Engineering, University of Port Harcourt

*Corresponding Author; Eme, Dennis Budu

ABSTRACT

This study was aimed at developing optimization models for the optimization and prediction of the indirect tensile strength of acidified-conventionally modified lateritic soils. The conventional materials used here are cement and hydrated lime. In this study, the modification process was carried out in three phases; using cement only, using lime only and lastly, using a combination of cement and lime in equal proportions. Hydrochloric acid (HCl) of low concentration was adopted for acidifying the lateritic soil by combining it with the mixing water. (4, 2) simplex lattice design of the mixture theory was adopted in development of the mix design. Scheffe's optimization procedure was employed during development of the indirect tensile strength (IDT) optimization models with the optimization done using solver in Microsoft excel. Developed models were subjected to validation and verification tests using F -statistics and R^2 statistics respectively. From the validation and verification analysis of the mathematical models, they proved adequate at 95% confidence level with their calculated F -values well below the critical F -value and their R^2 values were all above 90%. From the optimization study using excel solver, the optimum combination of constituents for cement-soil mixture resulting to a maximum IDT of 0.45115MPa, was obtained as; 93.3% for lateritic soil, 6.7% for cement, 6.67% for water, and 2% for acid. This indicates that the optimal acid proportion is 23.07% of mixing water. For lime-soil mix, a maximum IDT of 0.114728MPa was obtained for an optimum constituents' combination of 94.604% lateritic soil, 5.396% lime, 6.5396% water and 1.6195% for acid. This indicates that the optimal acid proportion is 19.849% of mixing water. The cement-lime-soil modification resulted in a maximum IDT of 0.33752MPa at an optimal combination of 93.30% for lateritic soil, 6.7% for cement-lime, 6.67% for water and 2% for acid, indicating that the optimal acid proportion is 23.07% of mixing water.

Keywords; indirect tensile strength, splitting cylinder test, simplex lattice theory, scheffe's optimization, acidified-soil

Received 25 Mar., 2023; Revised 05 Apr., 2023; Accepted 07 Apr., 2023 © The author(s) 2023.

Published with open access at www.questjournals.org

I. INTRODUCTION

The behavior of soils in tension is a subject of great interest, not only for geotechnical engineers, but also for other branches of engineering, such as agricultural or mining, where the main object is connected with tillage or with resistance during soil excavation. From the geotechnical engineering point of view, the interest with respect to the tensile strength of soils is very often connected with the different tensile cracks that can develop in earth structures, such as embankment dams, slopes, retaining walls from reinforced soil, or with a capping clay sealing system of sanitary landfills [1]. Tensile strength of soil is one important strength parameters in the field of soil mechanics and geotechnical engineering. However, it is always been overlooked by engineers because of its relatively small value as compared to the compressive strength. Tensile strength is usually measured by loading a cylindrical or prismatic or specially shaped specimen in tension to failure. Tensile strength are classified as either direct or indirect tensile tests. For the direct method, the tensile strength of soil is usually determined by uniaxial tensile tests ([2]; [3]).The tensile load is directly applied to the two ends of a soil specimen. Most of the direct tension tests on concrete, soils and brittle pavement materials suffer from either local stress concentration set up by devices used to grip the specimens or complicated processes for making and testing specimens. Premature failure was commonplace even when specially machined dumbbell shaped specimens were used. This led to the investigation of various indirect tensile tests as an alternative to direct methods for tensile strength measurement.Khalili et al. [4] stated that tests in the indirect tensile strength

testing category include; flexural (beam) test, double punch test, Brazilian split test or splitting cylinder test, ring tensile test and the non-Brazilian split test. Figure 1 shows the classification of tensile strength testing techniques.

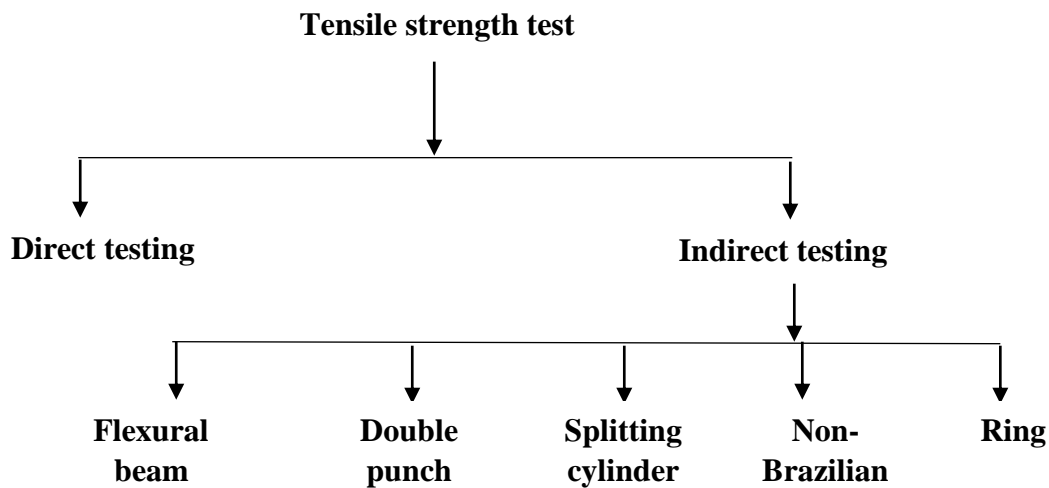

Figure 1. Classification of Tensile strength tests

1.1 Splitting Cylinder Tensile Strength Test

The splitting cylinder test, whose other common names are; Brazilian splitting test and diametral compression of cylinder test, is most commonly used for testing the tensile properties of rock, concrete and soils. Here, a cylindrical disk specimen of soil, placed horizontally, is subjected to a compressive force through two diametrically opposed rigid platens. The compressive force generates a tensile stress, perpendicular to the compressive force, along the plane between the two platens. The compressive force is increased until failure occurs along this plane. Based on an assumption of linear elasticity, along the loaded diameter, the tensile stress, σ_x is constant and represented by Equation (1).

$$\sigma_x = \frac{2P}{ndt} \quad (1)$$

Where, 'P' is the maximum vertical load applied in the test, 'd' is the diameter of the sample and 't', its thickness or height. The shear stress, τ_{xy} is zero along the loading plane, therefore σ_x and σ_y are the principal stresses.

As loading occurs the sample deforms at the loading interface, resulting in loading conditions changing from point loading to distributed-loading. As a consequence of this the stress distribution changes from the ideal tensile stress at the centre to a more complex combined stress. Determination of a tensile strength relies on the assumptions of linearly elastic behavior. Figure 2 shows the different failure patterns associated with the splitting cylinder testing technique [5]. The schematic representation of the splitting cylinder tensile strength test is shown by Figure 3 [5].

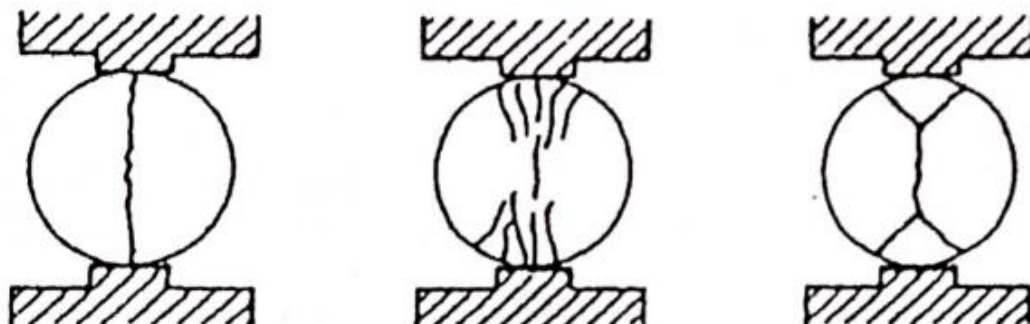

Figure 2. Failure patterns associated with splitting cylinder testing technique ([5])

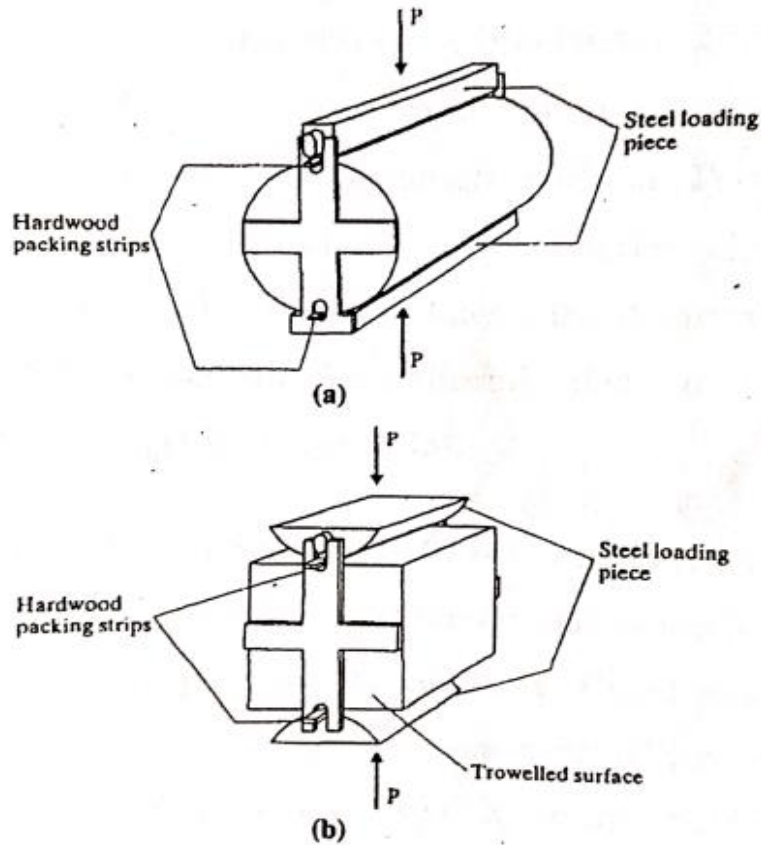

Figure 3. Schematics of the Splitting cylinder testing technique ([5])

1.2 Scheffe's Optimization Technique

Several authors ([6]; [7]; [8]; [9]) have carried out concrete mixture researches with development of mathematical models, most of which were based on Scheffe's Simplex theory. This is a theory where a polynomial expression is used to characterize a simplex lattice mixture components. In this theory only a single phase mixture is covered. The theory lends path to a unifying equation model capable of taking varying mix component variables to fix equal mixture properties. The optimization that follows selects the optimal ratio from the component ratios list that is automatically generated. The Scheffe's simplex lattice design theory have been employed by researchers in the optimization of properties of different substances obtained from component materials with encouraging results.

Jackson [10] defined a simplex as a structural representation (shapes) of lines or planes joining assumed points of constituent materials of a mixture and which such points are equidistant from each other. According to Oguaghamba and Mama [11], a (q, m) mixture, with q being the number of factors and m being the maximum number of component interactions or degree of assumed polynomial, the simplex coordinate system, X_i , and the number of design space points in the simplex lattice, N is defined by Equation (2) and Equation (3) respectively;

$$X_i = 0, \frac{1}{m}, \frac{2}{m}, \dots, 1 \quad (2)$$

$$N = \frac{(q+m-1)!}{m!(q-1)!} \quad (3)$$

The number of the design space points N, translates to the minimum number of experimental runs required for development of optimization model of a required mixture property. According to Scheffe[12], mixture proportions are being represented in pseudo (theoretical) mix ratios. Pure substance exist at the vertices points and the method rely on the condition that the summation of all pseudo mix ratios at any point must be equal to 1. Mathematically;

$$\sum_{i=1}^q X_i = 1 \quad (4)$$

To achieve the condition of Equation (4), actual mix ratios must be converted to pseudo mix ratios. The relationship between pseudo and actual mix ratios, according to Scheffe[12] is given by;

$$Z = [A]X \quad (5)$$

Where: Z = column matrix of real component ratio.

X = column matrix of pseudo component ratio.

[A]= coefficient matrix which is the transpose of the permutation matrix [P].

The permutation matrix is obtained from experience derived from reviewed literatures and/or intelligent guesses of the mixture proportions of the factors or mix components. For a (q, m) mixture, the general form of the polynomial model is [12];

$$Y = b_o + \sum b_i x_i + \sum b_{ij} x_i x_j + \sum b_{ijk} x_i x_j x_k + \dots + \sum b_{i_1, i_2, \dots, i_m} x_{i_1} x_{i_2} x_{i_m} \quad (6)$$

Where; $1 \leq i \leq q, 1 \leq i \leq j \leq q, 1 \leq i \leq j \leq k \leq q$

b_o is a constant coefficient

This study employed this technique for the development of optimization or prediction models to predict the indirect tensile strength determined through the splitting cylinder testing technique of acidified lateritic soils modified using cement and lime in different capacities.

II. MATERIALS AND METHODS

The lateritic soil with properties shown in Table 1 was modified using cement and lime in different capacities. Modification was done in three different phases; by using cement alone, using lime alone and then combining cement and lime in equal proportions with the incorporation of acid to the mixing water. This resulted to a total of four (4) component materials which are; lateritic soil, modifier, acid and water. The acid used here is low concentration hydrochloric acid (HCl). Table 2 presents the specific gravities of the cement and lime used for soil modification.

Table 1. Properties of untreated lateritic soil

Item	Value (description)
Specific gravity	2.71- representative of a fine grained material according to ASTM
Plasticity index	7.34%- a fine grained soil material with low plasticity
AASHTO classification	A-4 silty soil material
Grain distribution	
Medium sand	28%
Silt	6.2%
Fine sand	46%
Coarse sand	19.8%
Compaction characteristics	
Optimum moisture content (OMC)	8%
Maximum dry density (MDD)	1.29 g/cm ³
SiO ₂ /(Al ₂ O ₃ +Fe ₂ O ₃)	1.42

Table 2. Specific gravity of materials

Material	Specific gravity (G _s)
Lateritic soil	2.71
Cement	2.99
Lime	3.26

2.1 Design of Experiment (DoE) Development

For (4, 2) mixture, as employed in this study, X_i becomes 0, ½ and 1 while N becomes 10 on application of Equations (2) and (3) respectively. This gives rise to the (4, 2) simplex lattice presented in Figure 4.

In constructing the mix design tableau, the permutation matrix [P] in Equation (5) was determined from experience and reviews involving cement and lime modification of lateritic soil as available in literature. From experience of cement and lime soil modification design, the modifiers (cement and lime) contents were limited to 0-10% by dry weight of modified soil, limiting the lateritic soil content to the range of 90-100% of modifier-soil mix. Water content was varied in the range of 6-10% by weight of modifier-lateritic soil mix. This range was selected to account for the effect of the modifiers on lateritic soil as the optimum moisture content of natural lateritic soil was obtained as 8%. Furthermore, in order to study the effect of acidity on the modified lateritic soil, diluted HCl partially replaced water used for mixing of modifier-soil mix constituents. This partial replacement was limited to the range of 0-30% by weight of mixing water. These specified or adopted range of values were used in the development of the permutation matrix which represent the actual mix ratios of modifier-soil mixes at vertices positions. At these vertices points, the actual mixture components as specified by given ranges of constituents, can be deduced as; (1; 0; 0.06; 0), (0.967; 0.033; 0.0633; 0.01), (0.933; 0.067;

0.0667; 0.02), and (0.9; 0.10; 0.07; 0.03). These actual mix components are arranged in the format, (lateritic soil; modifier; water; acid). In matrix form, the mix ratio becomes the permutation matrix [P]. Thus;

$$[P] = \begin{bmatrix} 1.0000 & 0.0000 & 0.0600 & 0.0000 \\ 0.9670 & 0.0330 & 0.0633 & 0.0100 \\ 0.9330 & 0.0670 & 0.0667 & 0.0200 \\ 0.9000 & 0.1000 & 0.0700 & 0.0300 \end{bmatrix} \quad (7)$$

With the corresponding pseudo mix components being;

$$[X] = \begin{bmatrix} 1.000 & 0.000 & 0.000 & 0.000 \\ 0.000 & 1.000 & 0.000 & 0.000 \\ 0.000 & 0.000 & 1.000 & 0.000 \\ 0.000 & 0.000 & 0.000 & 1.000 \end{bmatrix} \quad (8)$$

The transpose of [P] becomes the coefficient matrix [A] as shown in Equation (3.10)

$$[A] = \begin{bmatrix} 1.0000 & 0.9670 & 0.9330 & 0.9000 \\ 0.0000 & 0.0330 & 0.0670 & 0.1000 \\ 0.0600 & 0.0633 & 0.0667 & 0.0700 \\ 0.0000 & 0.0100 & 0.0200 & 0.0300 \end{bmatrix} \quad (9)$$

Equation (5) was used to transform predetermined pseudo components to produce actual or real components for trial and control mixes shown in Table 3 and Table 4 respectively.

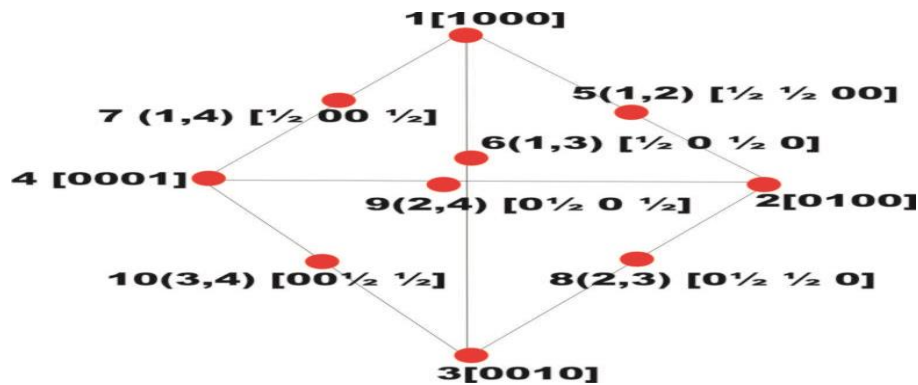

Figure 4. (4, 2) simplex lattice adopted for this study

Table 3: Design table for trial mixes

N	Pseudo component				Actual component			
	X ₁	X ₂	X ₃	X ₄	Z ₁	Z ₂	Z ₃	Z ₄
1	1	0	0	0	1.000	0.000	0.0600	0.000
2	0	1	0	0	0.967	0.033	0.0633	0.010
3	0	0	1	0	0.933	0.0670	0.0667	0.020
4	0	0	0	1	0.900	0.100	0.070	0.030
5	½	½	0	0	0.9835	0.0165	0.06165	0.005
6	½	0	½	0	0.9665	0.0335	0.06335	0.010
7	½	0	0	½	0.950	0.050	0.065	0.015
8	0	½	½	0	0.950	0.050	0.065	0.015
9	0	½	0	½	0.9335	0.0665	0.06665	0.020
10	0	0	½	½	0.9165	0.0835	0.06835	0.025

Where; X₁, Z₁= pseudo and actual component of lateritic soil; X₂, Z₂ = pseudo and actual component of modifier;

X₃, Z₃ = pseudo and actual component of water; X₄, Z₄ = pseudo and actual component of acid

Table 4: Design table for control mixes

N	Pseudo component				Actual component			
	X ₁	X ₂	X ₃	X ₄	Z ₁	Z ₂	Z ₃	Z ₄
1	0.25	0.25	0.25	0.25	0.95	0.05	0.065	0.015
2	0.2	0.2	0.3	0.3	0.9433	0.0567	0.06567	0.017
3	0.3	0.3	0.2	0.2	0.9567	0.0433	0.06433	0.013
4	0.2	0.2	0.2	0.4	0.94	0.06	0.066	0.018
5	0.1	0.3	0.3	0.3	0.94	0.06	0.066	0.018
6	0.35	0.3	0.2	0.15	0.9617	0.0383	0.06383	0.0115
7	0.15	0.45	0.15	0.25	0.9501	0.0499	0.06499	0.015
8	0.25	0.2	0.3	0.25	0.9483	0.0517	0.06517	0.0155

9	0.4	0.1	0.35	0.15	0.95825	0.04175	0.064175	0.0125
10	0.45	0.25	0.2	0.1	0.96835	0.03165	0.063165	0.0095

Where; X₁, Z₁= pseudo and actual component of lateritic soil; X₂, Z₂ = pseudo and actual component of modifier;

X₃, Z₃ = pseudo and actual component of water; X₄, Z₄ = pseudo and actual component of acid

2.2 Optimization Models' Development

For (4, 2) simplex problem, Equation (6) becomes;

$$Y = b_0 + b_1X_1 + b_2X_2 + b_3X_3 + b_4X_4 + b_{12}X_1X_2 + b_{13}X_1X_3 + b_{14}X_1X_4 + b_{23}X_2X_3 + b_{24}X_2X_4 + b_{34}X_3X_4 + b_{11}X_1^2 + b_{22}X_2^2 + b_{33}X_3^2 + b_{44}X_4^2 \quad (10)$$

For a ternary mixture, Equation (11) is obtained from Equation (4).

$$X_1 + X_2 + X_3 + X_4 = 1 \quad (11)$$

Multiplying through by constant b₀, yields Equation (12).

$$b_0X_1 + b_0X_2 + b_0X_3 + b_0X_4 = b_0 \quad (12)$$

Again, multiplying Equation (11) by X₁, X₂, X₃, X₄ and X₅ in succession and rearranging, Equation (13) is produced.

$$\begin{cases} X_1^2 = X_1 - X_1X_2 - X_1X_3 - X_1X_4 \\ X_2^2 = X_2 - X_1X_2 - X_2X_3 - X_2X_4 \\ X_3^2 = X_3 - X_1X_3 - X_2X_3 - X_3X_4 \\ X_4^2 = X_4 - X_1X_4 - X_2X_4 - X_3X_4 \end{cases} \quad (13)$$

Substituting Equations (12) and (13) into Equation (10), Equation (14) was obtained after necessary transformation.

$$Y = (b_0 + b_1 + b_{11})X_1 + (b_0 + b_2 + b_{22})X_2 + (b_0 + b_3 + b_{33})X_3 + (b_0 + b_4 + b_{44})X_4 + (b_{12} - b_{11} - b_{22})X_1X_2 + (b_{13} - b_{11} - b_{33})X_1X_3 + (b_{14} - b_{11} - b_{44})X_1X_4 + (b_{23} - b_{22} - b_{33})X_2X_3 + (b_{24} - b_{22} - b_{44})X_2X_4 + (b_{34} - b_{33} - b_{44})X_3X_4 \quad (14)$$

Denoting; $\beta_i = b_0 + b_i + b_{ii}$ and

$$\beta_{ij} = b_{ij} - b_{ii} - b_{jj}$$

The reduced second degree polynomial in 4 variables is shown by Equation (15).

$$Y = \beta_1X_1 + \beta_2X_2 + \beta_3X_3 + \beta_4X_4 + \beta_{12}X_1X_2 + \beta_{13}X_1X_3 + \beta_{14}X_1X_4 + \beta_{23}X_2X_3 + \beta_{24}X_2X_4 + \beta_{34}X_3X_4 \quad (15)$$

Substituting the vertices coordinates of Figure 4 into Equation (15) yields Equation (16)

$$\begin{cases} Y_1 = \beta_1 \\ Y_2 = \beta_2 \\ Y_3 = \beta_3 \\ Y_4 = \beta_4 \end{cases} \quad (16)$$

From Figure 4, Point X₁₂, Equation (17) can be deduced;

$$Y_{12} = \frac{1}{2}X_1 + \frac{1}{2}X_2 + \frac{1}{4}X_1X_2 \quad (17)$$

$$= \frac{1}{2}\beta_1 + \frac{1}{2}\beta_2 + \frac{1}{4}\beta_{12}$$

$\beta_i = Y_i$, where i = 1, 2, 3,n. Then substituting into Equation (15) yields:

$$Y_{12} = (\frac{1}{2})Y_1 + (\frac{1}{2})Y_2 + (\frac{1}{4})\beta_{12} \quad (18)$$

Simplifying Equation (18), yields:

$$\beta_{12} = 4Y_{12} - 2Y_1 - 2Y_2 \quad (19)$$

Similarly, Equation (20) to Equation (22) can be developed. Thus:

$$\beta_{13} = 4Y_{13} - 2Y_1 - 2Y_3 \quad (20)$$

$$\beta_{14} = 4Y_{14} - 2Y_1 - 2Y_4 \quad (21)$$

$$\beta_{23} = 4Y_{23} - 2Y_2 - 2Y_3 \quad (22)$$

By generalizing, Equations (16) to (22), Equation (23) is formed.

$$\left. \begin{aligned} \beta_i &= Y_i \\ \beta_{ij} &= 4Y_{ij} - 2Y_i - 2Y_j \end{aligned} \right\} \text{of the (4, 2) second degree polynomial in Equation (15).} \quad (23)$$

2.3 Indirect Tensile strength test (Splitting cylinder test);

The splitting cylinder test was used as the measure of the indirect tensile strength in this study. This splitting cylinder test was conducted in accordance to [5]. Prepared samples of modified lateritic soil samples were cured

using the membrane procedure for a duration of 28 days. The indirect tensile strength was then, evaluated mathematically using Equation (1).

III. RESULTS AND DISCUSSION

3.1 Models' Formulation

Acidified Cement- lateritic soil

The coefficients of tensile strength optimization model for acidified cement-soil mix obtained using Equation (23) and information from Table 5 are;

$$\beta_1 = 0.03676; \beta_2 = 0.06684; \beta_3 = 0.45115; \beta_4 = 0.41773; \beta_{12} = -0.00668$$

$$\beta_{13} = -0.76194; \beta_{14} = 0.40102; \beta_{23} = 0.23390; \beta_{24} = 0.14034; \beta_{34} = -0.18716$$

Substituting the above coefficient values into Equation (15), the optimization model for predicting the tensile strength of acidified cement modified lateritic soil becomes;

$$IDT_{cement-soil} = 0.03676X_1 + 0.06684X_2 + 0.45115X_3 + 0.41773X_4 - 0.00668X_1X_2 - 0.76194X_1X_3 + 0.40102X_1X_4 + 0.2339X_2X_3 + 0.14034X_2X_4 - 0.18716X_3X_4 \quad (24)$$

Acidified lime- lateritic soil

The coefficients of tensile strength optimization model for acidified lime-soil mix obtained using Equation (23) and information from Table 6 are;

$$\beta_1 = 0.03676; \beta_2 = 0.06015; \beta_3 = 0.04344; \beta_4 = 0.05347; \beta_{12} = -0.10026$$

$$\beta_{13} = -0.04008; \beta_{14} = 0.24730; \beta_{23} = 0.24730; \beta_{24} = 0.14704; \beta_{34} = 0.12698$$

Substituting the above coefficient values into Equation (15), the optimization model for predicting the tensile strength of acidified lime modified lateritic soil becomes;

$$IDT_{lime-soil} = 0.03676X_1 + 0.06015X_2 + 0.04344X_3 + 0.05347X_4 - 0.10026X_1X_2 - 0.04008X_1X_3 + 0.24730X_1X_4 + 0.24730X_2X_3 + 0.14704X_2X_4 + 0.12698X_3X_4 \quad (25)$$

Acidified cement-lime- lateritic soil

The coefficients of tensile strength optimization model for acidified cement-lime-soil mix obtained using Equation (23) and information from Table 7 are;

$$\beta_1 = 0.03676; \beta_2 = 0.07352; \beta_3 = 0.33752; \beta_4 = 0.32416; \beta_{12} = 0.22056; \beta_{13} = -0.34756$$

$$\beta_{14} = 0.30744; \beta_{23} = 0.23392; \beta_{24} = 0.0334; \beta_{34} = -0.52132$$

Substituting the above coefficient values into Equation (15), the optimization model for predicting the tensile strength of acidified cement-lime modified lateritic soil becomes;

$$IDT_{cement-lime soil} = 0.03676X_1 + 0.07352X_2 + 0.33752X_3 + 0.32416X_4 + 0.22056X_1X_2 - 0.34756X_1X_3 + 0.30744X_1X_4 + 0.23392X_2X_3 + 0.0334X_2X_4 - 0.52132X_3X_4 \quad (26)$$

Table 5: Acidified cement-soil tensile strength results for trial mixes

N	Pseudo component				Actual component				Response symbol	IDT(MPa)
	X ₁	X ₂	X ₃	X ₄	Z ₁	Z ₂	Z ₃	Z ₄		
1	1	0	0	0	1.000	0.000	0.0600	0.000	Y ₁	0.03676
2	0	1	0	0	0.967	0.033	0.0633	0.010	Y ₂	0.06684
3	0	0	1	0	0.933	0.0670	0.0667	0.020	Y ₃	0.45115
4	0	0	0	1	0.900	0.100	0.070	0.030	Y ₄	0.41773
5	½	½	0	0	0.9835	0.0165	0.06165	0.005	Y ₁₂	0.05013
6	½	0	½	0	0.9665	0.0335	0.06335	0.010	Y ₁₃	0.05347
7	½	0	0	½	0.950	0.050	0.065	0.015	Y ₁₄	0.32750
8	0	½	½	0	0.950	0.050	0.065	0.015	Y ₂₃	0.31747
9	0	½	0	½	0.9335	0.0665	0.06665	0.020	Y ₂₄	0.27737
10	0	0	½	½	0.9165	0.0835	0.06835	0.025	Y ₃₄	0.38765

Where; X₁, Z₁ = pseudo and actual component of lateritic soil; X₂, Z₂ = pseudo and actual component of modifier;

X₃, Z₃ = pseudo and actual component of water; X₄, Z₄ = pseudo and actual component of acid

Table 6: Acidified lime-soil tensile strength results for trial mixes

N	Pseudo component				Actual component				Response symbol	IDT(MPa)
	X ₁	X ₂	X ₃	X ₄	Z ₁	Z ₂	Z ₃	Z ₄		
1	1	0	0	0	1.000	0.000	0.0600	0.000	Y ₁	0.03676
2	0	1	0	0	0.967	0.033	0.0633	0.010	Y ₂	0.06015

3	0	0	1	0	0.933	0.0670	0.0667	0.020	Y ₃	0.04344
4	0	0	0	1	0.900	0.100	0.070	0.030	Y ₄	0.05347
5	½	½	0	0	0.9835	0.0165	0.06165	0.005	Y ₁₂	0.02339
6	½	0	½	0	0.9665	0.0335	0.06335	0.010	Y ₁₃	0.03008
7	½	0	0	½	0.950	0.050	0.065	0.015	Y ₁₄	0.10694
8	0	½	½	0	0.950	0.050	0.065	0.015	Y ₂₃	0.11362
9	0	½	0	½	0.9335	0.0665	0.06665	0.020	Y ₂₄	0.09357
10	0	0	½	½	0.9165	0.0835	0.06835	0.025	Y ₃₄	0.08020

Where; X₁, Z₁= pseudo and actual component of lateritic soil; X₂, Z₂ = pseudo and actual component of modifier;

X₃, Z₃ = pseudo and actual component of water; X₄, Z₄ = pseudo and actual component of acid

Table 7: Acidified cement-lime-soil tensile strength results for trial mixes

N	Pseudo component				Actual component				Response symbol	IDT(MPa)
	X ₁	X ₂	X ₃	X ₄	Z ₁	Z ₂	Z ₃	Z ₄		
1	1	0	0	0	1.000	0.000	0.0600	0.000	Y ₁	0.03676
2	0	1	0	0	0.967	0.033	0.0633	0.010	Y ₂	0.07352
3	0	0	1	0	0.933	0.0670	0.0667	0.020	Y ₃	0.33752
4	0	0	0	1	0.900	0.100	0.070	0.030	Y ₄	0.32416
5	½	½	0	0	0.9835	0.0165	0.06165	0.005	Y ₁₂	0.11028
6	½	0	½	0	0.9665	0.0335	0.06335	0.010	Y ₁₃	0.10025
7	½	0	0	½	0.950	0.050	0.065	0.015	Y ₁₄	0.25732
8	0	½	½	0	0.950	0.050	0.065	0.015	Y ₂₃	0.26400
9	0	½	0	½	0.9335	0.0665	0.06665	0.020	Y ₂₄	0.20719
10	0	0	½	½	0.9165	0.0835	0.06835	0.025	Y ₃₄	0.20051

Where; X₁, Z₁= pseudo and actual component of lateritic soil; X₂, Z₂ = pseudo and actual component of modifier;

X₃, Z₃ = pseudo and actual component of water; X₄, Z₄ = pseudo and actual component of acid

3.2 Models' validation and verification

Models developed were subjected to Fisher test (F-test) for validation and adequacy check at 95% confidence level. The F-statistics is given as the ratio of variance between the predicted/model response value and that of experimental value. The following hypothesis were adopted in validation of models;

Null Hypothesis: H₀ = there is no significant difference between the experimental and predicted responses.

Alternate Hypothesis: H₁= there is a significant difference between the experimental and predicted responses.

Mathematically, the F-test is represented by Equation (27).

$$F = \frac{S_1^2}{S_2^2} \tag{27}$$

Where; S₁² = Larger of both variances

S₂² = Smaller of both variance

S² is obtained from Equation (28)

$$S^2 = \frac{1}{n-1} [\sum(Y - \bar{Y})^2] \tag{28}$$

Where : \bar{Y} = Average mean of response, Y

Y = Means of response

The models developed were declared adequate if the F-value calculated in accordance to Equation (27) is less than tabulated value (from F-distribution table) for a degree of freedom of N-1.

Validation and verification of tensile strength model for acidified cement-soil

Table 8 presents the results of the tensile strength of acidified cement-soil for the control mixes used for validation of the tensile strength optimization model (Equation 24) alongside the model values. Table 9 presents the F- statistics for the acidified cement-soil tensile strength model validation. With the aid of Table 9 and Equation (27) the following was deduced;

$$S_e^2 = 0.03275/9 = 0.003639; \quad S^m^2 = 0.02754/9 = 0.003060$$

Thus;

$$F = 0.003639/0.003060 = 1.19$$

Because F-cal(1.19) is less than F-tab (3.18), the null hypothesis is accepted and the model is considered adequate.

Furthermore, the R² statistics displayed in Figure 5 revealed an R² value of 97.78%. This indicates that over 97% of the data set is explained by the optimization model.

Validation and verification of tensile strength model for acidified lime-soil

Table 10 presents the results of the tensile strength of acidified lime-soil for the control mixes used for validation of the tensile strength optimization model (Equation 25) alongside the model values. Table 11 presents the F- statistics for the acidified lime-soil tensile strength model validation. With the aid of Table 11 and Equation (27) the following was deduced;

$$S_e^2 = 0.0145/9 = 0.000161; \quad S^{m^2} = 0.00112/9 = 0.000124$$

Thus;

$$F = 0.000161/0.000124 = 1.30$$

Because F-cal(1.30) is less than F-tab (3.18), the null hypothesis is accepted and the model is considered adequate.

Furthermore, the R² statistics displayed in Figure 6 revealed a R² value of 94.02%. This indicates that just over 94% of the data set is explained by the optimization model.

Validation and verification of tensile strength model for acidified cement-lime-soil

Table 12 presents the results of the tensile strength of acidified cement-lime soil for the control mixes used for validation of the tensile strength optimization model (Equation 26) alongside the model values. Table 13 presents the F- statistics for the acidified cement-lime soil tensile strength model where the predicted values were tested for adequacy. With the aid of Table 13 and Equation (27) the following was deduced;

$$S_e^2 = 0.00527/9 = 0.000585; \quad S^{m^2} = 0.004454/9 = 0.000495$$

Thus;

$$F = 0.000585/0.000495 = 1.18$$

Because F-cal(1.18) is less than F-tab (3.18), the null hypothesis is accepted and the model is considered adequate.

Furthermore, the R² statistics displayed in Figure 7 revealed a R² value of 96.64%. This indicates that over 96% of the data set is explained by the optimization model.

Table 8: Acidified cement-soil tensile strength results for control mixes

N	Pseudo component				Actual component				Response symbol	IDT (MPa)	
	X ₁	X ₂	X ₃	X ₄	Z ₁	Z ₂	Z ₃	Z ₄		Exp. value	Pred. value
1	0.25	0.25	0.25	0.25	0.95	0.05	0.065	0.015	CP1	0.22724	0.23184
2	0.2	0.2	0.3	0.3	0.9433	0.0567	0.06567	0.017	CP2	0.26066	0.26507
3	0.3	0.3	0.2	0.2	0.9567	0.0433	0.06433	0.013	CP3	0.20719	0.19757
4	0.2	0.2	0.2	0.4	0.94	0.06	0.066	0.018	CP4	0.30745	0.28499
5	0.1	0.3	0.3	0.3	0.94	0.06	0.066	0.018	CP5	0.30745	0.29020
6	0.35	0.3	0.2	0.15	0.9617	0.0383	0.06383	0.0115	CP6	0.16709	0.16756
7	0.15	0.45	0.15	0.25	0.9501	0.0499	0.06499	0.015	CP7	0.2239	0.22970
8									CP8	0.23393	0.23693
	0.25	0.2	0.3	0.25	0.9483	0.0517	0.06517	0.0155			
9	0.4	0.1	0.35	0.15	0.95825	0.04175	0.064175	0.0125	CP9	0.15707	0.15954
10	0.45	0.25	0.2	0.1	0.96835	0.03165	0.063165	0.0095	CP10	0.12699	0.12544

Where; X₁, Z₁ = pseudo and actual component of lateritic soil; X₂, Z₂ = pseudo and actual component of modifier;

X₃, Z₃ = pseudo and actual component of water; X₄, Z₄ = pseudo and actual component of acid

Table 9. F-Statistics for validation of acidified cement soil tensile strength optimization model

Exp. Value=Y _e	Pred. Value=Y ^m	Y _e -Y _e	Y ^m -Y ^m	(Y _e -Y _e) ²	(Y ^m -Y ^m) ²
0.22724	0.23184	0.00534	0.01295	2.9E-05	0.00016782
0.26066	0.26507	0.03876	0.04619	0.0015	0.00213338
0.20719	0.19757	-0.0147	-0.02132	0.00022	0.00045435
0.30745	0.28499	0.08555	0.06611	0.00732	0.00437002
0.30745	0.29020	0.08555	0.07132	0.00732	0.00508627
0.16709	0.16756	-0.0548	-0.05132	0.003	0.00263423
0.2239	0.22970	0.002	0.01082	4E-06	0.00011698

Optimizing the Indirect Tensile Strength of Acidified-Conventionally Modified Lateritic Soils

0.23393	0.23693	0.01203	0.01805	0.00014	0.00032583
0.15707	0.15954	-0.0648	-0.05935	0.0042	0.00352183
0.45983	0.45002	-0.1283	-0.14303	0.01647	0.02045738
$\hat{Y}_e=0.58816$	$\hat{Y}^m=0.59305$			$\Sigma=0.06307$	$\Sigma=0.06071$

Table 10: Acidified lime-soil tensile strength results for control mixes

N	Pseudo component				Actual component				Response symbol	IDT (MPa)	
	X ₁	X ₂	X ₃	X ₄	Z ₁	Z ₂	Z ₃	Z ₄		Exp. value	Pred. value
1	0.25	0.25	0.25	0.25	0.95	0.05	0.065	0.015	CP1	0.09357	0.09273
2	0.2	0.2	0.3	0.3	0.9433	0.0567	0.06567	0.017	CP2	0.10025	0.09678
3	0.3	0.3	0.2	0.2	0.9567	0.0433	0.06433	0.013	CP3	0.08681	0.08541
4	0.2	0.2	0.2	0.4	0.94	0.06	0.066	0.018	CP4	0.10694	0.09865
5	0.1	0.3	0.3	0.3	0.94	0.06	0.066	0.018	CP5	0.1036	0.10333
6	0.35	0.3	0.2	0.15	0.9617	0.0383	0.06383	0.0115	CP6	0.07686	0.07815
7	0.15	0.45	0.15	0.25	0.9501	0.0499	0.06499	0.015	CP7	0.09023	0.09387
8									CP8	0.09691	0.09278
	0.25	0.2	0.3	0.25	0.9483	0.0517	0.06517	0.0155			
9	0.4	0.1	0.35	0.15	0.95825	0.04175	0.064175	0.0125	CP9	0.0802	0.07791
10	0.45	0.25	0.2	0.1	0.96835	0.03165	0.063165	0.0095	CP10	0.06684	0.06765

Where; X₁, Z₁= pseudo and actual component of lateritic soil; X₂, Z₂ = pseudo and actual component of modifier; X₃, Z₃ = pseudo and actual component of water; X₄, Z₄ = pseudo and actual component of acid

Table 11. F-Statistics for validation of acidified lime soil tensile strength optimization model

Exp. Value= \hat{Y}_e	Pred. Value= \hat{Y}^m	$\hat{Y}_e - \hat{Y}_e$	$\hat{Y}^m - \hat{Y}^m$	$(\hat{Y}_e - \hat{Y}_e)^2$	$(\hat{Y}^m - \hat{Y}^m)^2$
0.09357	0.09273	0.00335	0.00401	1.1E-05	0.00001606
0.10025	0.09678	0.01003	0.00805	0.0001	0.00006481
0.08681	0.08541	-0.0034	-0.00331	1.2E-05	0.00001097
0.10694	0.09865	0.01672	0.00992	0.00028	0.00009846
0.1036	0.10333	0.01338	0.01460	0.00018	0.00021318
0.07686	0.07815	-0.0134	-0.01058	0.00018	0.00011194
0.09023	0.09387	9E-06	0.00514	8.1E-11	0.00002646
0.09691	0.09278	0.00669	0.00406	4.5E-05	0.00001646
0.0802	0.07791	-0.01	-0.01082	0.0001	0.00011698
0.06684	0.06765	-0.0234	-0.02107	0.00055	0.00044411
$\hat{Y}_e=0.090221$	$\hat{Y}^m=0.08873$			$\Sigma=0.00145$	$\Sigma=0.00112$

Table 12: Acidified cement-lime soil tensile strength results for control mixes

N	Pseudo component				Actual component				Response symbol	IDT (MPa)	
	X ₁	X ₂	X ₃	X ₄	Z ₁	Z ₂	Z ₃	Z ₄		Exp. value	Pred. value
1	0.25	0.25	0.25	0.25	0.95	0.05	0.065	0.015	CP1	0.18046	0.18839
2	0.2	0.2	0.3	0.3	0.9433	0.0567	0.06567	0.017	CP2	0.20051	0.19610
3	0.3	0.3	0.2	0.2	0.9567	0.0433	0.06433	0.013	CP3	0.17712	0.17805
4	0.2	0.2	0.2	0.4	0.94	0.06	0.066	0.018	CP4	0.20719	0.20906
5	0.1	0.3	0.3	0.3	0.94	0.06	0.066	0.018	CP5	0.21053	0.20679
6	0.35	0.3	0.2	0.15	0.9617	0.0383	0.06383	0.0115	CP6	0.16041	0.16592
7	0.15	0.45	0.15	0.25	0.9501	0.0499	0.06499	0.015	CP7	0.19048	0.18886
8									CP8	0.1838	0.18697
	0.25	0.2	0.3	0.25	0.9483	0.0517	0.06517	0.0155			
9	0.4	0.1	0.35	0.15	0.95825	0.04175	0.064175	0.0125	CP9	0.14036	0.14874

10	0.45	0.25	0.2	0.1	0.96835	0.03165	0.063165	0.0095	CP10	0.14704	0.14431
----	------	------	-----	-----	---------	---------	----------	--------	------	---------	---------

Where; X₁, Z₁= pseudo and actual component of lateritic soil; X₂, Z₂ = pseudo and actual component of modifier;

X₃, Z₃ = pseudo and actual component of water; X₄, Z₄ = pseudo and actual component of acid

Table 13. F-Statistics for validation of acidified cement-lime soil tensile strength optimization model

Exp. Value=Y _e	Pred. Value=Y ^m	Y _e -Y _e	Y ^m -Y ^m	(Y _e -Y _e) ²	(Y ^m -Y ^m) ²
0.18046	0.18839	0.00067	0.00707	4.5E-07	0.00005003
0.20051	0.19610	0.02072	0.01478	0.00043	0.00021833
0.17712	0.17805	-0.0027	-0.00327	7.1E-06	0.00001069
0.20719	0.20906	0.0274	0.02774	0.00075	0.00076966
0.21053	0.20679	0.03074	0.02547	0.00094	0.00064870
0.16041	0.16592	-0.0194	-0.01540	0.00038	0.00023718
0.19048	0.18886	0.01069	0.00754	0.00011	0.00005686
0.1838	0.18697	0.00401	0.00565	1.6E-05	0.00003195
0.14036	0.14874	-0.0394	-0.03258	0.00155	0.00106134
0.14704	0.14431	-0.0328	-0.03701	0.00107	0.00136941
Y _e =0.17979	Y ^m =0.18132			Σ=0.00527	Σ=0.004454

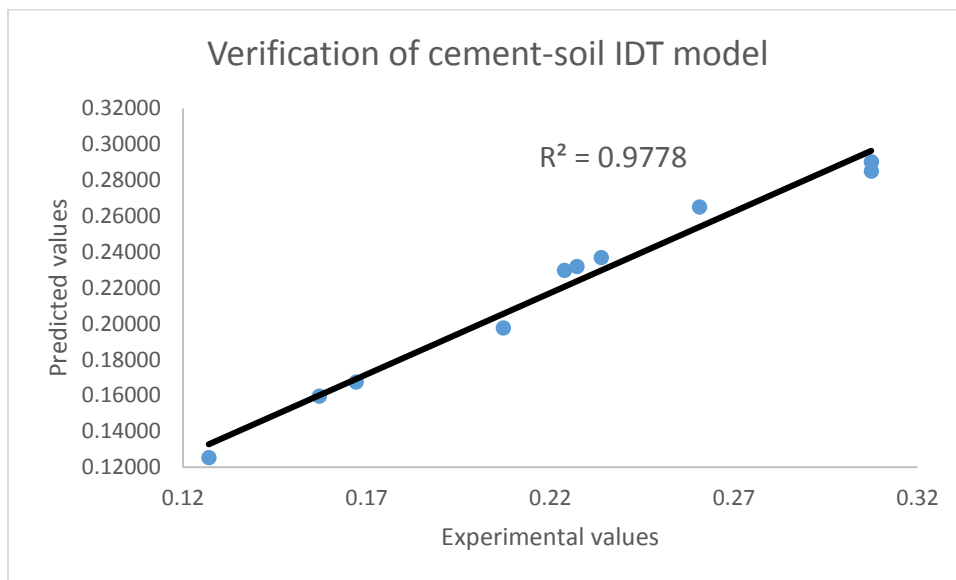

Figure 5. R² Statistics of acidified cement-soil tensile strength model

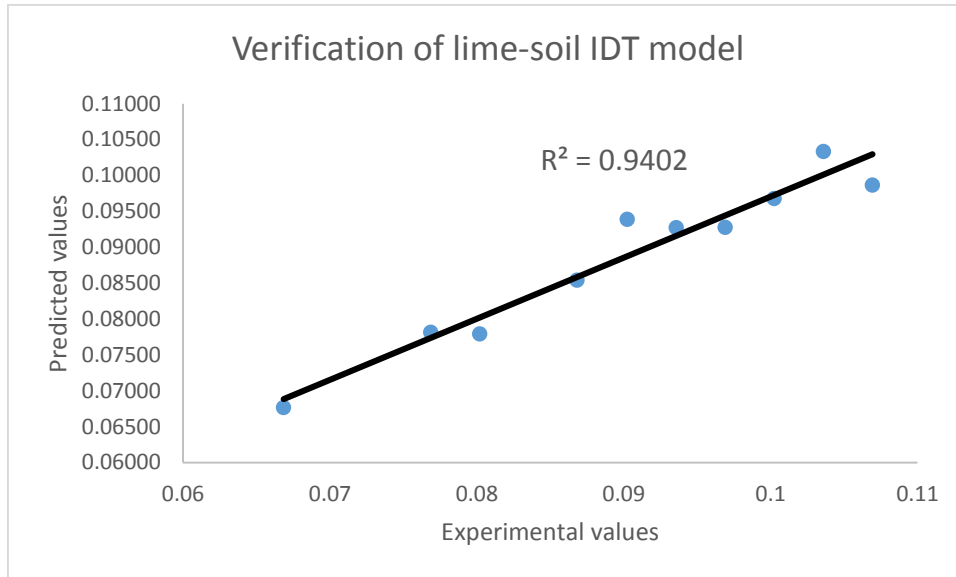

Figure 6. R² Statistics of acidified lime-soil tensile strength model

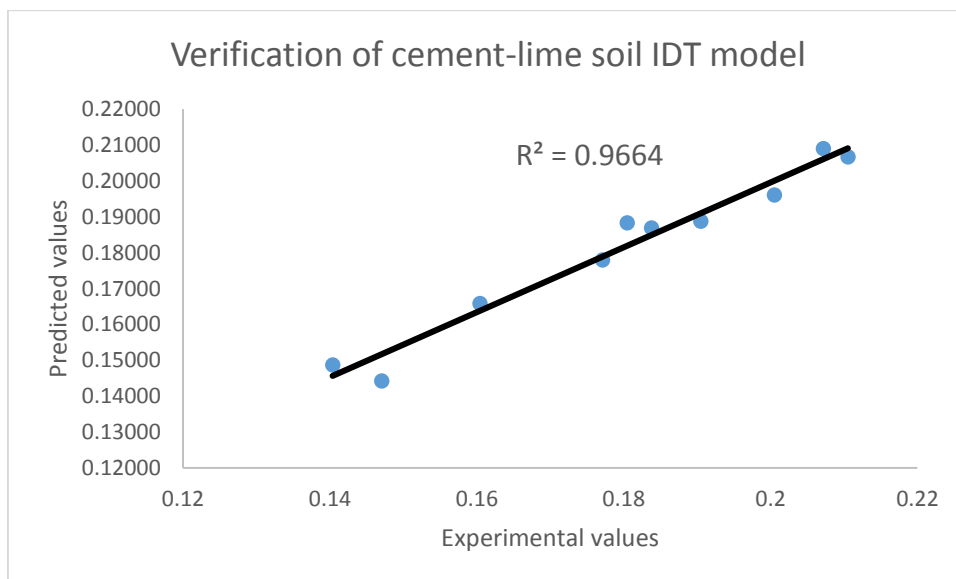

Figure 7. R² Statistics of acidified cement-lime soil tensile strength model

3.3 Optimization of Developed Models

Optimization or combination of constituent materials to yield the best performing modified lateritic soil using the Microsoft excel solver, is hereby presented in this section.

Optimization of tensile strength of acidified lateritic soil modified using cement

In optimization, there must be an objective function subjected to a set of constraints. Here, Objective function;

Maximize; Equation (24)

Subjected to the following constraints;

$$X_1 + X_2 + X_3 + X_4 = 1$$

$$X_1, X_2, X_3, X_4 \geq 0$$

Using the conditions above, the pseudo proportions of constituents was obtained as; $X_1 = 0$; $X_2 = 0$; $X_3 = 1$ and $X_4 = 0$; with **Max (IDT) = 0.45115 MPa**. On application of the transformation equation (Equation 5);

$$\begin{bmatrix} 1.0000 & 0.9670 & 0.9330 & 0.9000 \\ 0.0000 & 0.0330 & 0.0670 & 0.1000 \\ 0.0600 & 0.0633 & 0.0667 & 0.0700 \\ 0.0000 & 0.0100 & 0.0200 & 0.0300 \end{bmatrix} X = \begin{bmatrix} 0 \\ 0 \\ 1 \\ 0 \end{bmatrix} = \begin{bmatrix} 0.933 \\ 0.067 \\ 0.0667 \\ 0.02 \end{bmatrix}$$

The actual or real constituent proportions is obtained as; 93.3% for lateritic soil, 6.7% for cement, 6.67% for water, and 2% for acid. This indicates that the optimal acid proportion is 23.07% of mixing water.

Optimization of tensile strength of acidified lateritic soil modified using lime

In optimization, there must be an objective function subjected to a set of constraints. Here, Objective function;

Maximize; Equation (25)

Subjected to the following constraints;

$$\mathbf{X}_1 + \mathbf{X}_2 + \mathbf{X}_3 + \mathbf{X}_4 = 1$$

$$\mathbf{X}_1, \mathbf{X}_2, \mathbf{X}_3, \mathbf{X}_4 \geq 0$$

Using the conditions above, the pseudo proportions of constituents was obtained as; $\mathbf{X}_1= 0$; $\mathbf{X}_2= 0.485515$; $\mathbf{X}_3= 0.409423$ and $\mathbf{X}_4 = 0.105062$; with **Max (IDT) = 0.114728 MPa**. On application of the transformation equation (Equation 5);

$$\begin{bmatrix} 1.0000 & 0.9670 & 0.9330 & 0.9000 \\ 0.0000 & 0.0330 & 0.0670 & 0.1000 \\ 0.0600 & 0.0633 & 0.0667 & 0.0700 \\ 0.0000 & 0.0100 & 0.0200 & 0.0300 \end{bmatrix} X \begin{bmatrix} 0 \\ 0.485515 \\ 0.409423 \\ 0.105062 \end{bmatrix} = \begin{bmatrix} 0.94604 \\ 0.05396 \\ 0.065396 \\ 0.016195 \end{bmatrix}$$

The actual or real constituent proportions is obtained as; 94.604% for lateritic soil, 5.396% for lime, 6.5396% for water, and 1.6195% for acid. This indicates that the optimal acid proportion is 19.849% of mixing water.

Optimization of tensile strength of acidified lateritic soil modified using cement and lime

In optimization, there must be an objective function subjected to a set of constraints. Here, Objective function;

Maximize; Equation (26)

Subjected to the following constraints;

$$\mathbf{X}_1 + \mathbf{X}_2 + \mathbf{X}_3 + \mathbf{X}_4 = 1$$

$$\mathbf{X}_1, \mathbf{X}_2, \mathbf{X}_3, \mathbf{X}_4 \geq 0$$

Using the conditions above, the pseudo proportions of constituents was obtained as; $\mathbf{X}_1= 0$; $\mathbf{X}_2= 0$; $\mathbf{X}_3= 1$ and $\mathbf{X}_4 = 0$; with **Max (IDT) = 0.33752 MPa**. On application of the transformation equation (Equation 5);

$$\begin{bmatrix} 1.0000 & 0.9670 & 0.9330 & 0.9000 \\ 0.0000 & 0.0330 & 0.0670 & 0.1000 \\ 0.0600 & 0.0633 & 0.0667 & 0.0700 \\ 0.0000 & 0.0100 & 0.0200 & 0.0300 \end{bmatrix} X \begin{bmatrix} 0 \\ 0 \\ 1 \\ 0 \end{bmatrix} = \begin{bmatrix} 0.933 \\ 0.067 \\ 0.0667 \\ 0.02 \end{bmatrix}$$

The actual or real constituent proportions is obtained as; 93.30% for lateritic soil, 6.7% for cement-lime, 6.67% for water, and 2% for acid. This indicates that the optimal acid proportion is 23.07% of mixing water.

IV. CONCLUSION

In this study partial replacement of mixing water with 0-30% low concentrated hydrochloric acid for cement and lime modified soils in different capacities was carried out with the main focus of determining the 28th day tensile strength via the splitting cylinder technique of the modified soils. Three modes of lateritic soil modification was carried out; using only cement, using only lime and lastly using a combination of cement and lime in equal proportions.

Optimization models using the Scheffe's optimization technique which is based on the theory of simplex lattice were developed for the different modes of acidified lateritic soil modifications. All the developed models proved adequate at 95% confidence level. Their F-calculated values were all well below the tabulated or critical F-value obtained from the F-distribution table. Experimental and model values also agreed superbly with their R² values all well above 90%.

From the optimization analysis using the Microsoft excel solver, the optimum proportions for acidified cement-soil mix is; 93.3% for lateritic soil, 6.7% for cement, 6.67% for water, and 2% for acid. This indicates that the optimal acid proportion is 23.07% of mixing water. For acidified lime-soil mix, the optimum proportions is; 94.604% for lateritic soil, 5.396% for lime, 6.5396% for water, and 1.6195% for acid. This indicates that the optimal acid proportion is 19.849% of mixing water. For acidified cement-lime soil mix, the optimum proportions is obtained as; 93.30% for lateritic soil, 6.7% for cement-lime, 6.67% for water, and 2% for acid. This indicates that the optimal acid proportion is 23.07% of mixing water.

REFERENCES

- [1]. Vanicek I, (2013). 'The importance of tensile strength in geotechnical engineering', ActaGeotechnicaSolvenica, pp 5-17.
- [2]. Lu N., Wu B., and Tan C.P., (2007). 'Tensile strength characteristics of unsaturated sands', J. Geotech. Geoenviron. Eng.,10.1061/(ASCE) 1090-0241, 133:2(144), 144-154.
- [3]. Tang C., Pei X., Wang D., Shi B., and Li J., (2015) 'Tensile strength of compacted clayey soil', J. Geotech. Geoenviron. Eng., 10.1061/(ASCE) GT.1943-5606.0001267, 133:2 (141).
- [4]. Khalili N., Russel A., and Khoshghalb A., (2014) 'Unsaturated Soils: Research & Applications', CRC Press, 824-825.
- [5]. BS 1881: Part 117(1983). Standard Specification for Determination of Split Tensile Strength (BS 1881: Part 117). London; British Standard Institution.

- [6]. Onyia, M. E. (2017). Optimization of the cost of lateritic soil stabilized with quarry dust. *Int. J. Sci. Eng. Res.*, 8(9), 1400–1413.
- [7]. Anya, C. U. (2015). Models for predicting the structural characteristics of sand-quarry dust blocks. Ph.D Thesis, Department of Civil Engineering, University of Nigeria, Nsukka.
- [8]. Okere, C. E. Onwuka, D. O. Onwuka, S. U. and Arimanwa, J. I. (2013). Simplex-based concrete mix design. *IOSR J. Mech. Civ. Eng.*, 5(2), 46–55.
- [9]. Mbadike, E. M. and Osadebe, N. N. (2014). Five component concrete mix optimization of aluminum waste using Scheffe's theory. *Int. J. Comput. Eng. Res.*, 4(4), 23– 31.
- [10]. Jackson, N. (1983). *Civil Engineering Materials*, RDC. Arter Ltd, Hong Kong.
- [11]. Oguaghamba O. A. and Mama, B. O. (2018) "Generalized Scheffe's second degree mathematical models approach in engineering mixture design," in 16th Intern. Conf. & AGM of Nigerian Institute of Civil Engineers on Transforming National Economy through Sustainable Civil Engineering Infrastructures – Engineering Solutions to Problematic Soils and Allied Construction Materials, NICE, Calabar, October 24 – 26, pp. 32–44.
- [12]. Scheffe, H. (1958). "Experiments with Mixtures". *Royal Statistical Society Journal*". Series B. 20, 344-360.