



Research Paper

Variance Analysis & Performance of Kaduna State Water Corporation

Ibrahim A. Muhammad ^{1*}, Dr. E S Abi ^{2*}, Dr. L O Mustapha ^{3*} &
Dr Yahya O. A. ^{4*}

Department of Accounting, Faculty of Management Sciences, Nigerian Defence Academy, Kaduna, Nigeria

Abstract

There is always fluctuation in prices of goods and services up or down within the Nigeria that leads either surplus or deficit to be made. Standard must be used to compare between the budgeted transactions and the actual. The main objective of this study is to determine the effect of variance analysis & performance of Kaduna State Water Corporation. Variance analysis is the explanatory variable proxied by Labour variance or performance and Customer satisfaction; while organizational performance was proxied by innovation. The study use 2057 staff under Kaduna Water corporation in Kaduna metropolis (Human resources Department; Divisional Office Zaria, 2021)., while sample of 324 respondents was arrived after filtering invalid questionnaires. Descriptive research design, questionnaires, construct reliability and validity and multiple regression technique with the help of SPSS and PLS 2.0 was applied in the data analysis. The findings of the study revealed that Labour variance and Customer satisfaction has positive significant effect on organizational performance. The study concluded that variance analysis has influence on performance of Kaduna State Water Corporation. The study recommended Kaduna State Water Corporation used variance analysis in order to compare the differences between variance proxies performances that are actual with standard, maintain, adjust or improve the standard and performance of Kaduna State Water Corporation.

Keywords: *Variance, Labour Variance and Customer Satisfaction*

Received 10 May, 2022; Revised 22 May, 2022; Accepted 24 May, 2022 © The author(s) 2022.

Published with open access at www.questjournals.org

I. Introduction

In any financial commitment normally for a prize, the costs that are accidental to it very well may be extensively investigated into material, work and upward. This is on the grounds that material is generally expected in any creation cycle; work is one more prerequisite to meet the compensation payable to the laborers and, thirdly, overheads which are treated as circuitous costs and are either factor or fixed. Nonetheless, in a help arranged business, accentuation on costs will be fundamentally not quite the same as say an assembling outfit as it will be more on work and upward. Cost of material will ordinarily be disregarded as no natural substance will be expected to do an administration bookkeeping consultancy administration, for instance. For an association to earn back the original investment and continue to record benefit, costs should be checked and controlled so they can be inside satisfactory cutoff points. Cost control must be advanced by an association in light of the significant tensions of rivalry (ICAN, 2006).

However, expenses and real execution are clearly required for compelling administration control in costs decrease and evasion through squander in any structure to upgrade an association's turnover and profit. This is accomplished through setting of a norm in every component of cost in an action cycle. The activity of a standard costing framework will be expected for: i) the exact planning of standard expenses and ii) correlation of standard with real expenses and the ordinary survey of norms (Lynch, 2005). The aftereffects of contrasting the standard expenses and genuine exhibitions seldom concur regardless of the practicability of the standard expenses set up. There are generally contrasts alluded to as Variances. Nonetheless, when the change happens, it ought not be a base for reprimanding the exhibition of the chief or administrator controlling the expenses, rather it is a notification to the administration that an exemption for the norm or financial plan has happened and may require examination and potentially clarification to change ensuing expenses for control reason. To limit the size of the expense difference and work on the presentation, administrators are supposed to be effectively engaged with giving data and setting the norm rather than the board alone.

Investigation of variances is the main occupation in the legitimate execution of a standard expense framework. Cost differences are simply insignificant figures except if sufficiently broke down and astutely deciphered. Just thanks to this logical gadget would the figures be able to recount the tale of what's going on and guide the way toward progress methodology. Here is the place where the standard expense framework leaves the domain of specialized bookkeeping and dull charges and credits and enters the environment of interpretive and imaginative examination for the executives direction. Variance is a term utilized for the contrast between real expense and standard expense. An ideal variance happens assuming genuine expenses are not exactly standard expense. Customarily, great difference is expected to suggest proficient execution. A horrible difference emerges on the off chance that genuine expense surpasses standard expense. A horrible change should demonstrate wasteful execution. Moreover, including the administrators and other faculty straightforwardly engaged with setting guidelines could make the advantageous inspiration, and responsibility that could set off them to be effective to accomplish the principles created by them. By and by, the methodology might contrast and be troublesome as the board alone and potentially with few others might rule or assume control over the obligation of these specialized directors. When this opportunity of giving data and support in the standard setting is denied, it might lead to age of excessive change. The investigation of related costs will then become complicated. The normal result can make liberal or slack standard costs that wouldn't reflect productive guidelines. This along these lines could shape the reason for conflict with what is feasible or practical. This is clear since directors or administrators can't be anticipated to execute an arrangement except if they know and are important for what is involved (ICAN, 2006).

As indicated by Pandey (2005), there are two sorts of changes, specifically: Favorable and Unfavorable Variances: Where the genuine expense is not exactly standard expense, it is known as "good" or "credit" difference. Then again, where the genuine expense is more than standard expenses, the thing that matters is alluded to as "horrible" or "antagonistic" or "charge" difference. All in all, any change that well affects benefit is positive difference and any variances which meaningfully affects benefit is troublesome difference. Expecting that standard expenses have been accurately set, positive difference is an impression of effectiveness and troublesome variances demonstrates failure. Controllable and Uncontrollable Variances: If a difference can be viewed as the obligation of a specific individual with the outcome that his level of productivity can be reflected in its size, then, at that point, being a controllable variance is said. For instance, abundance use of material is typically, the obligation of the foreman concerned. Be that as it may, assuming the unnecessary utilization is because of material being inadequate, the obligation might rest with the Inspection Department for non-recognition of the imperfections. Assuming that a difference emerges because of specific variables past the control of the executives, it is known as wild fluctuation. For instance, change in the market costs of materials, general expansion in the work rates, expansion in the paces of force or insurance installment, and so forth are not inside the control of the administration of the organization. Obligation regarding wild difference can't be doled out to any individual or office. The division of difference into controllable and wild is critical. The administration ought to put more accentuation on controllable difference as it is these changes which require examination and potentially restorative activity. The controllable differences, then again, might be disregarded. Notwithstanding, whether execution is truly productive or wasteful will be known just when changes are investigated exhaustively by their causes.

Statement of the Problem

The word variance will address the contrast between the standard expense of creation and the real expense of creation or the distinction between the planned income and the genuine income. The most common way of grouping a given change into its sub-difference is depicted as fluctuation examination. A given change might be deciphered to address antagonistic or great for the association relying upon the distinctions. For instance, a given change will address antagonistic of the standard expense of creation is lower than the real expense of creation or planned income is viewed as higher than the real income. Then again, a fluctuation will be perceived to mean positive for the association in the event that the standard expense of creation is higher than the genuine expense of creation or the planned benefit is lower than the real benefit. The focal point of this study is to offer an experimental proof on how fluctuation investigation assists with laboring expense at Kaduna Water Corporation.

Objectives of the Study

The two main objectives of the study are:

- i. To what extent has variance analysis has affect labour execution in Kaduna Water Corporation standard.
- ii. To see if change examination upgrades the executives improvement in tasks of Kaduna Water corporation.

Research Hypotheses

For the purpose of this study the following hypotheses are considered relevant.

1. Variance analysis significantly help in providing directions to the causes of Kaduna Water Corporation standard performance.
2. Variance analysis enhances management improvement in operations at Kaduna Water Corporation.

Scope of the Study

The scope of the study is limited to application of variance analysis at Kaduna Water Corporation board in Kaduna State located in Kaduna, Zaria, and Kafachan. The task of this study was on imperatives of variance analysis for cost control in Kaduna Water Corporation.

II. Literature Review

Concept of Variance Analysis in Perspective

Arora (2006) characterizes change investigation as the method involved with breaking down differences by partitioning the absolute fluctuation so that administration can dole out liability regarding any off-standard presentation. As indicated by I.C.M.A. London, phrasing, difference investigation is the goal into constituent parts and the clarification of Variances . A significant part of difference examination is the need to isolate controllable from wild variances . A point by point examination of controllable differences will assist the administration with recognizing the people answerable for its event so remedial move can be made. Idornigie (2005) sees change as the deviations of genuine execution from standard execution. They are marks of unacceptable execution or super-standard execution. Whenever the expenses of genuine movement are higher than the standard expense we have unfavorable change. Going against the norm, when the genuine expenses are lower than the norm (expected) cost we have ideal change. Positive differences highlight proficiency while negative or unfavorable changes highlight shortcoming.

Types of Variance

As indicated by Pandey (2005), there are two kinds of fluctuation. They are:

1. Good and Ominous Variances: When the real expense is not exactly standard expense, it is known as "ideal" or "credit" change. Then again, where the genuine expense is more than standard expense, the thing that matters is alluded to as "negative" or "unfriendly" or "charge" change. As such, any fluctuation that well affects benefit is good difference and any change which affects benefit is troublesome difference. Expecting that standard expenses have been accurately set, good change is an impression of productivity and horrible fluctuation demonstrates shortcoming.
2. Controllable and Wild Variances: "On the off chance that a change can be viewed as the obligation of a specific individual with the outcome that his level of proficiency can be reflected in its size, then being a controllable variance is said". For instance, abundance use of material is generally, the obligation of the foreman concerned. Nonetheless, on the off chance that the extreme use is because of material being inadequate, the obligation might rest with the Assessment Division for non-discovery of the imperfections. On the off chance that a change emerges because of specific variables past the control of the board, it is known as wild difference.

For instance, change in the market costs of materials, general expansion in the work rates, expansion in the paces of force or insurance installment, and so on are not inside the control of the administration of the organization. Obligation regarding wild difference can't be allocated to any individual or division. The division of difference into controllable and wild is critical. The administration ought to put more accentuation on controllable difference as it is these changes which require examination and potentially restorative activity. The controllable changes, then again, might be disregarded. This follows the notable rule of exemption by which those matters which are going right are not offered consideration and any deviations from effective execution are explored.

Wellsprings of Change

As per Jhingan (2004) Variances will emerge from the accompanying sources: Material Changes

1. Value Differences
 - a. Addressing sequential cost than arranged.
 - b. Acquiring amount limits by purchasing bigger request amounts than arranged.
 - c. Purchasing sequential grade/nature of materials than arranged.
 - d. Purchasing substitute materials whose cost is not the same as the arranged.
 - e. Alarm purchasing
2. Use Change
 - a. Nature of materials
 - b. Substitute materials
 - c. Specialized productivity

- d. Human productivity or expertise
- e. Pilferage
- f. Contrast in yield from that arranged.

Work Changes

- 1. Rate Change
 - a. Work unionism and higher rates.
 - b. Various grades of work utilized.
 - c. Change in labor compensation technique.
 - d. Change in technique for creation which might require various grades of work input.
- 2. Effectiveness Change
 - a. Change in activity strategy office utilized by work which influences proficiency.
 - b. Grade of work utilized.
 - c. Studio association.
 - d. Ampleness of oversight.
 - e. Grade of materials utilized.
 - f. Working condition.

General Causes Outside the particular reason recorded above, changes can by and large emerge from the accompanying sources:

- a. Improper or inaccurately set guidelines.
- b. Wrong execution of standard set as when pretty much IS input than standard.
- c. Mis-estimation of genuine outcomes.

Targets and Meaning of Difference Examination

Arora (2006) recorded the three targets of difference examination to include: execution assessment, cost control and the executives by exemption. A firm working a standard expense framework ascertains differences for every component of cost for which guidelines have been set. Whenever variances have been determined, they are investigated to decide:

- 1. Where did variance happen?
- 2. Which cost components were at fluctuation with norms and by what sum?
- 3. What were the reasons for the events of differences?
- 4. Who were answerable for differences? Such an examination accordingly draws out the meaning of variances regarding their sources, causes and obligation.
 - a. Fluctuation investigation framework helps in assessing individual exhibitions by featuring the distinction concerning costs between achieved execution and
 - b. Difference investigation helps in doling out liabilities to people. Reasonably set principles give challenge to people and propel them to accomplish the exhibition targets.
 - c. A fluctuation investigation framework, joined with a fitting revealing instrument assists the board with depending on the standard of the executives by special case. Reasonably pre-arranged change reports call top administration consideration just to outstanding Variances .

Changes running between specific breaking point are arranged off at lower levels of the board. The difference reports are likewise dense so that administration can get the ramifications of variances a definite and tedious investigation of number of statistical data points.

Research Methodology

This chapter presents the research design, population and sample of the study, sources and method of data collection, techniques of data analysis, data validity and reliability.

Research Design

This research will adopt descriptive research design. The essence for descriptive is because, it all allows for questions to be structured clearly and investigated. Cooper (2003).

Population of the Study

The population of this study is 2,057 of staff under Kaduna Water corporation in Kaduna metropolis (Human resources Department; Divisional Office Zaria, 2021).

Sample Size

For this study, the decision of the respondent that participate is assume that 50/50 chances are more justifiable than 80/20 for a more homogenous sample (Dilman, 2007). Also, the population proportion of this study is 0.5 which represents the sampling error of the population. Hence, in this study, the sampling error is 0.05, which is to say about +5 percent of the actual population. Finally, C=Z statistic which is associated with

the confidence level of 1.96 that corresponds 95 percent level of significance. Therefore, the sample size of this study is determined using Dilman's Formula for determining sample size (2007) as shown below:

Dilman's Formula for Determining Sample Size (2007)

$$NS = \frac{(NP)(P)(1 - P)}{(NP - 1)(B / C)^2 + (P)(1 - 0.5)}$$

Where:

NS= Complete sample size needed for desired level of precision.

NP = Size of population

P = The population proportion expected to choose among the two response categories.

B = Sample error

C = Confidence level

Solution

$$NP = 2,057$$

$$P = 0.5$$

$$B = 0.05$$

$$C = 1.96$$

$$NS = \frac{(2057)(0.5)(1 - 0.5)}{(2057 - 1)(0.05 / 1.96)^2 + (0.5)(1 - 0.5)}$$

$$NS = \frac{(2057)(0.5)(0.5)}{(2056)(0.0007) + (0.5)(0.5)}$$

$$NS = \frac{(2057)(0.25)}{1.33798374 + 0.25}$$

$$NS = \frac{514.25}{1.58798374} = 323.8$$

$$NS = 324^*$$

The calculation above for the study sample size using Dilma (2007) formula shows three hundred and twenty-four (324).

In addition for the purpose of anticipated non-response bias and non-return of completed questionnaire. The questionnaire was increased by 20% and added to the above minimum size given by the formula to make it 389. This will also take care of other and failure of some respondents to return the questionnaires (Isreal, 2013).

Hence, in the present study, the number of sample size was increased by (20%) twenty percent as shown below:

Where:

Y= unknown increase of 20%

1 = Constant

324 = Actual sample size

100 = Percentage

$$Y = \frac{1}{324} \times \frac{20}{100}$$

Cross multiply

$$Y = \frac{324 \times 20}{100 \times 1}$$

$$Y = \frac{6480}{100} = 64.8 = 65^*$$

The (20%) twenty percent of the study sample size is 65 added to the original sample which is 324 Sample Size. As such, new sample size that has been drawn from the study population is 389 MSMEs. However, instead of 324 which is the original sample size, 389 questionnaires will be distributed to the randomly registered sampled MSMEs owners in Zaria metropolis.

Sampling Techniques

Probability sampling was employed for this research. A probability sampling is a form of sampling where a larger population are chosen through the use of the theory of probability. A random selection is used for any participant that is considered. Therefore, for this study, a simple random sampling was used.

Sources and Method of Data Collection

Primary method of data collection was used in this research and the tool that was used for data collection was questionnaire techniques method.

Technique of data analysis:

For the purpose of this study, partial least squares (PLS) technique was employed as a technique of data analysis. It gives the room for the research model to be tested with a minimum time or once. (Halawi & Mccarthy, 2008). However, the demographic profiles of the respondents was analyzed using descriptive statistics in SPSS. And the smart PLS 2.0 which is based on path modeling and boots trapping (Wet zels, Odekerken, Schroder & Van Oppen, 2009) was used to test the specified model of the study.

Data Validity and Reliability

The way for a researcher to know that the right instrument was used to gain result and that it is in line with two major criteria, is for the researcher to employ Data Validity and Reliability. This is the essence why the study uses validity and reliability [Ojo, 2003].

Variable Measurement

In this study, items measuring each construct were adopted and modified from previous studies. For example, independent variable (labour variance or performance) was adopted from the work of Sageeta Arora & Sapna Arora (2012). Customer satisfaction was adopted from Kemboi, Biwoth & Tarus (2014). On the other hand, the dependent variable MSMEs performance (innovation) was adopted from Datar, Kulp & Lambert (2012).

Thus, all the items were presented on a five point Likert Scale ranging from strongly agree (5) to strongly disagree (1). The questionnaire was divided into three sections. All questions were close ended form and all response was measured using 5 – point Likert Scale ranging from strongly disagree (SD), to strongly agree (SA). The use of Likert Scale has often been necessary because it is an interval scale that enables researcher to analyze questionnaire responses and give the respondent access to choose among multiple options.

Data Presentation and Analysis

This section presented the data collected, analysed and interpreted the results. The data were analyzed using SPSS and Smart PLS-SEM 2.0. In this chapter, response rate is presented and analyzed. The chapter also reported respondents’ profiles in terms of their gender, age, working experience, level of education. Data cleansing, reliability analysis, mean, standard deviation, correlation and regression analysis were utilized to summarized the responses of the research participants on the variables investigated. Correlation analysis is the statistical tool used to describe the degree to which variables are linearly related to another, the Pearson correlation coefficient range of 0.91-1.00 indicates very strong correlation, 0.71-0.90 indicates a high correlation, 0.41-0.70 indicates moderate correlation, 0.21-0.40 indicates small but definite correlation and 0.00-0.20 indicates slight, almost negligible correlation (Kumar & Eng, 2011).

Response rate

Table 4.1

Response rate of the questionnaire	
Detail	Copies/rate
Questionnaire distributed	389
Questionnaire returned	377
Questionnaire not returned	12
Invalid	5
Usable questionnaire	370
Response rate	0.98
Valid response rate	95.12%

Table 1 shows the summary of the number of questionnaires distributed, number of questionnaires returned and the response rate. The researcher distributed a total number of 389 questionnaires to participants, 377 questionnaires were returned and this gives a response rate of 98%. In a further assessment of the returned questionnaires, it was ascertained that 5 were invalid and this bring the total valid response rate to 95.12%. This rate is relatively high and this is because of the effort made by the researchers and assistants of constantly visiting the participated Kaduna water Corporation.

Data cleansing and preliminary analysis

The first issues concerning the accuracy of the data collected is to subject the data generated to data screening (Tabachnic et'al 2013). This is to ensure minimal distortion that possibly can be caused by inaccurate data. On the basis of this, data collected were screened for missing values; outlier detection and preliminary test were carried out for normality and multicollinearity.

Missing values

In missing value analysis, Sekaran (2004) recommended for exclusion of questionnaire(s) with up to 25% unanswered items, Hair et'al (2013) provided a threshold of 10% as maximum acceptable missing values. Using the frequency in SPSS descriptive statistics, the result of the missing value is shown in the table below.

Constructs	Items	No of Missing
Bio data	Gender	15
Experience	5	
Income	3	
Qualification	1	
Occupation	1	
Labour	Ln1	3
Ln3	1	
Ln4	1	
Customer satisfaction	Cs2	1
Cs3	1	
Performance (Innovation)	Pi4	1

Table 2 presented the missing values identified by our analysis as well as the items affected. From the table, Gender recorded 15 missing values, Experience 5, Income 3, Qualification 1 while Occupation 1. While from the variable of labour standard has a total missing value of 5, customer satisfaction 2 while performance has 1 and these combined gave a total of 35 missing values of 31,651 data points. This indicated that about 0.11% missing values in the entire data points.

Measurement model (outer model)

The figure and table 4.2 below presents the measurement model of the study. In the table, loadings of items of individual construct are show including composite reliability (CR) for internal consistency and Average Variance extracted (AVE) for construct validity.

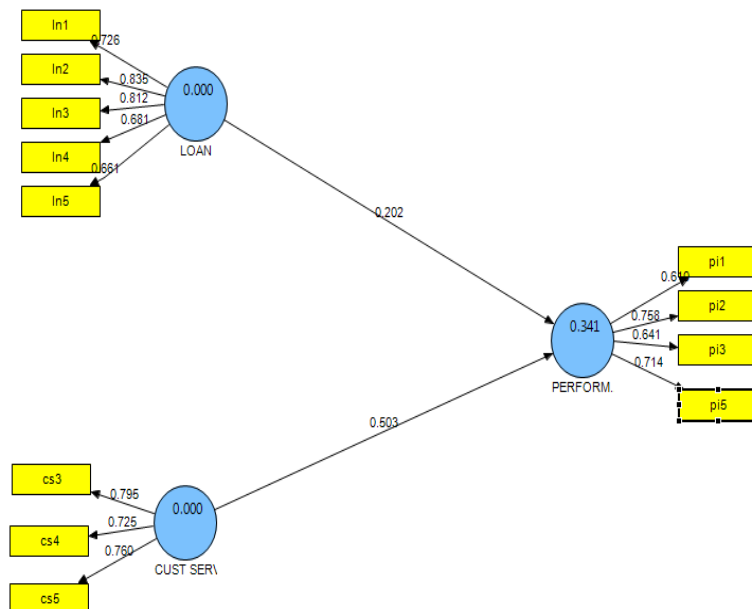

Figure 2
Measurement model

Table 7

Construct reliability and validity					
Construct	Items	Loadings	CR	AVE	
Labour	Ln1	0.726		0.861720	0.5570
	Ln2	0.835			
	Ln3	0.812			
	Ln4	0.681			
	Ln5	0.661			
Cust Satisfaction	Cs3	0.759		0.8040	0.5779
	Cs4	0.725			
	Cs5	0.760			
Performance	Pi1	0.610		0.776524	0.50
	Pi2	0.758			
	Pi3	0.641			
	Pi4				
	Pi5	0.714			

From the table 7, loadings of items measuring individual construct were greater than .5 which is a minimum recommended value as contained in Hair et'al (2013). However, items that failed this benchmark were deleted, they include Cs1 and Cs2 for customer satisfaction as well as Pi4 for innovative performance details of their loading are attached as appendix v to this study. All the constructs in the study met the composite reliability benchmark of .7 and average variance extracted of .5.

Also, for discriminant validity the study utilized the fornell and larker criterion which states that the square root of AVE must be greater than the correlation with other variable in the study. This is as presented in table 4.8 below

Table 8

Discriminant validity			
Construct	CS	LN	Pi
Customer satisfaction (Cs)	1		
Labour (Lb)	0.230	1	
Performance (Pi)	0.550	0.318	1

The square roots of AVE are presented in bolded font on the diagonal and it can be observed that the values are greater than the correlations among the constructs, thus this criterion is satisfied.

Structural model (Inner model)

The second part of the model is the structural model or inner model, Hair et' al. (2013) identified four key criteria for assessing the structural model in PLSSEM. These include assessments of significance of the path coefficients, coefficient of determination (R²), the effect size (f²), and lastly (4) predictive relevance (Q²). However, to ascertain the direct effect of labour standard, and customer satisfaction on innovative performance of Kaduna Water Corporation, it is important to carry out a bootstrapping analysis. Bootstrapping was done by using 5000 subsamples using 355 cases. Figure 4.2 presented the structural model of the direct effects.

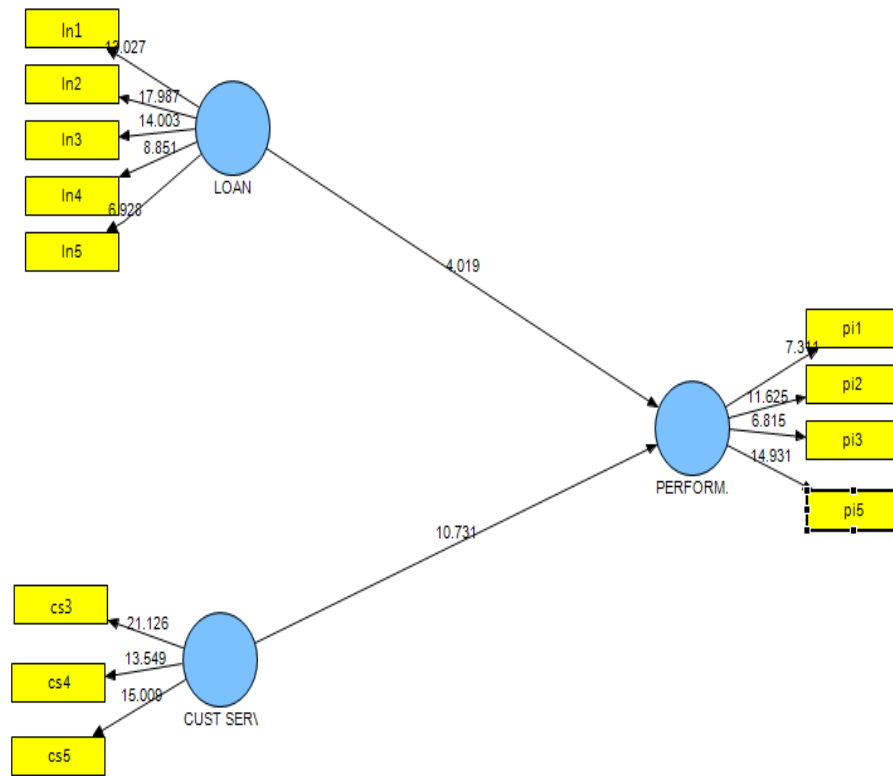

Figure 4.3
Structural model for direct relations

Test of hypotheses

The study tested the two hypotheses. Thus, Table 9 presented the results of the structural model with the beta value of the relationships, t-statistic and adjusted r square.

Table 9

Path coefficient for direct relationship						
Hypotheses	Relationship	Beta Value	Standard error	T Stat	p-value	Decision
H ₁	CS => PF	0.503	0.047	10.731	0.00***	Rejected
H ₂	LN => PF	0.202	0.050	4.019	0.00***	Rejected
R²		0.341				

***p<0.01, **p<0.05, *p<0.1

From Table 4.9, it can be seen that customer satisfaction has a significant positive effect on performance ($\beta = 0.503$, t-value = 10.731 p-value < 0.1). This means a unit increase in customer satisfaction will lead to 50.3% increase in variance analysis performance. Thus, the first hypothesis (H1) that Variance analysis significantly help in providing directions to the causes of Kaduna Water Corporation standard performance is accepted.

Also, labour service delivery has a significant positive effect on variance performance ($\beta = 0.202$ and t-value = 4.019, p-value < 0.01). This means as Customer satisfaction increases by one unit, variance analysis performance increases by 20.2%. As a result this is consistent with the findings of Okoh, L. O. & Uzoka P. (2019), Ejasari, Nurhasanah, Chairunnisa & Siregar (2019), Letitia Fourie (2015), Aniefor Sunday J. & Iboru Ogbena Godday (2015). Hence, hypothesis two (H2) that states that variance analysis performance has no

significant effect on organization performance is unsupported. And this is consistent with the study conducted by Lineal Makundi (2015), Aniefor Sunday J. & Iboro Ogbena Godday (2015).

Table 10

Effect size for direct relationship

Construct	R2 Included	R2 Excluded	f ²	Effect Size
Customer satisfaction	0.34	0.491	0.503	Large
Labour performance	0.34	0.797	0.202	Medium

Apart from evaluating the R² value of the endogenous variable of this model (i.e., firm performance), the change in the value of an R² when a particular exogenous variable is excluded from the model is used to assess whether an omitted variable has any substantive impact on that latent endogenous variable. Thus, this measure is termed as effect size (Hair et al., 2014). However, the effect size specifies the relative effect of a specific exogenous latent variable on the latent endogenous variable based on the changes in the R² value as a result of excluding the former (Chin, 1998). Consequently, the effect size is measured using Cohen's formula (see Cohen, 1988; Hair et al., 2014; Selya, Rose, Dierker, Hedeker, & Mermelstein, 2012; Wilson, Callaghan, Ringle, & Henseler, 2007) given as:

$$F^2 = \frac{R2\text{ Included} - R2\text{ Excluded}}{1 - R2\text{ Included}}$$

Where:

F² is the F-square value that determines the effect size of a specific exogenous on the endogenous. R² Included is the R² value of the endogenous variable before omitting a particular exogenous construct. And lastly, R² Excluded represents the changes in the R² value of the endogenous variable after excluding a particular exogenous variable from a model. Based on the above formula, the f² values of 0.02, 0.15, and 0.35, indicate Kaduna Water Cooperation are large effects respectively (Cohen, 1988).

From table 10, the effect size of customer satisfaction on innovative performance is 50.3% and this indicated large effect size on the endogenous variable. while labour has a medium effect size of 20.2% on innovative performance.

III. Conclusion

The study examined the imperatives of variance analysis for labour performance in Kaduna Water Corporation- An empirical study of Kaduna State, Nigeria. The study revealed that there is positive and significant relationship between variance analyses in providing directions to the causes of non-performance i.e labour performance as against standard performance which result to enhancing management improvement in operations. The study forward to provide recommendation base on the finding in order to improve the standard of the organization.

IV. Recommendations

Taking into account the discoveries and finish of the review, the accompanying proposals are, be that as it may, suggested for sound difference examination in associations.

- i. Variances should be based up logically settled principles. This suggests that expenses of work and administrations conveyance ought to be ordered and kept in a fair-minded and deliberate way in order to improve the off chance that execution of policy to be significant, variance can't be a significant proportion of execution and Objective standards should exist for estimating information sources and results of the Kaduna Water Company.
- ii. The organization should investigate the framework ought to be' intended to pinpoint the obligation focal point of every division of the association. Norms ought to be set and changes ought to be examined for every obligation place and the amount of result ought to be plainly characterized, the quantitative estimation of result ought to be exact.

References

- [1]. Adeniji, A. A. (2009). Cost accounting: A managerial approach (1st ed), Lagos: El-Toda Ventures Limited.
- [2]. Adeniji, A.A. (2013). Ad Insight into Management Accounting, Lagos: El toda Ventures.
- [3]. Arora, A.M. (2006). A Textbook on Cost Accountancy, New Delhi: Vikas Publishers.
- [4]. Batty, J. (1982). Management accountancy (5th ed), Bungay, Suffolk: Macdonald & Evans Ltd.
- [5]. Blocher, E. J., Chen, K. H., Cokins, G. & Lin, T. W. (2005). Cost management: A strategic emphasis (3rd ed), Boston: McGraw-Hill Irwin.
- [6]. Colander, D. (2004). On the treatment of fixed and sunk costs in the principles textbooks. Journal of Economic Education 35 (3): 360-364.

- [7]. Dandago, K. I. & Tijjani, B. (2005). Cost and Management Accounting (2nd ed). Kano – Nigeria: Gidan Dabino Publishers
- [8]. Eferakeya, I. (2013). Cost Accounting, Benin: Jones Publishers.
- [9]. Glautier, M. W. E. & Underdown, U. (2001). Accounting theory and practice (7th ed), Essex, England: FT Prentice Hall.
- [10]. Hilton, R. W. (2005). Managerial Accounting: Creating value in a dynamic business environment (6th ed). New York: McGraw Hill Irwin
- [11]. Horngren, C. T. (1978). Accounting for management control: An in introduction. Prentice Hall.
- [12]. Idornigie, G.A. (2005). Cost Accounting, Port Harcourt: Dekabeti Publishers.
- [13]. Institute of Chartered Accountants of Nigeria (ICAN) (2006). Cost accounting, Study Pack for Intermediate Examination, Lagos: VI Publishing Limited.
- [14]. Jhingan, M.L. (2004). Managerial Economics, New Delhi: Virinda Publications.
- [15]. Marburger, D. (2008). Reconciling cost theory with cost accounting practices. Arkansas State University, <http://ssrn.com/abstract=1138851>
- [16]. Omolehinwa, E. O. (2007). Coping with cost accounting. Nigeria: Pumarck Nigeria Limited
Owler, L. W. J. & Brown, J. L. (1982). Wheldon's costing accounting and costing methods (14th ed). London: The English Language Book Society and Macdonald and Evans.
- [17]. Pandey; I.M. (2005). Elements of Management Accounting, New Delhi: Vikas Publishers.
- [18]. Zimmerman, J. L. (2006). Accounting for decision making and control, New York: McGraw-Hill Irwin.