



Research Paper

The Effect of Budget Planning On Organizational Performance Through Standard Cost Analysis In The General Bureau Of The Regional Secretariat Of West Sulawesi Province

Subriyah¹, Nurdin Brasit², Darmawati³

¹⁾ Master of Regional Finance, Faculty of Economics and Business, Hasanuddin University

²⁾ Department of Management, Faculty of Economics and Business, Hasanuddin University

³⁾ Accounting Department, Faculty of Economics and Business, Hasanuddin University

ABSTRACT: This study aims to analyze and explain the influence of budget planning on organizational performance through cost standards at the General Bureau of the Regional Secretariat of West Sulawesi Province. The data used in this study is primary data using a questionnaire. This research is a quantitative research, because the research data is in the form of numbers and the analysis uses statistics with the research design of a hypothesis testing study to test the effect between variables. The research uses Path Analysis using the AMOS program. The research sample amounted to 72 respondents. The results show that: Budget Planning, Budget Evaluation, and Cost Standards have direct and indirect effects on Organizational Performance at the General Bureau of the Regional Secretariat of West Sulawesi Province.

KEYWORDS: Budget Planning, Budget Evaluation, Cost Standards and Organizational Performance.

Received 08 November, 2021; Revised: 22 November, 2021; Accepted 24 November, 2021 © The author(s) 2021. Published with open access at www.questjournals.org

I. Introduction:-

The performance achieved by an organization is basically the achievement of the members of the organization itself, starting from the top level to the bottom level. The concept of local government performance itself emerged when government institutions began to try to introduce new concepts in the management of public affairs into good governance. A successful organization is an organization that has a clear and measurable vision and mission. This means that the vision and mission will not be meaningful when they are not actualized in organizational performance within the framework of creating good governance (Anggraeni, 2009).

In an effort to achieve a good organizational performance, it is necessary to have a good, directed, and comprehensive work plan, so that it is easy for management to control the operational activities of the organization. The results are presented in a budget prepared by management based on targets that are tailored to the conditions and needs of the organization, the period is one year, or the period is more than one year, and is prepared in a certain format (Salbiah and Rizky, 2012).

The budgeting stage is a very important stage because an ineffective and not performance-oriented budget can actually frustrate programs that have been prepared previously. Often encountered in practice, budget preparation seems to be a separate part from strategic formulation and planning so that the success of budget implementation is not in line with the success of programs and organizational goals. Budgeting like this cannot produce an effective budget as a management tool to bridge the achievement of organizational goals (Basri, 2013) Related to the budget management process by government officials which is not optimal so that it results in organizational performance, which should receive attention from the local government where the local government as a recipients of authority in managing the organization need to do their best to achieve organizational goals in this case the achievement of good organizational performance.

Budgeting problems that have occurred in each region, in the process of preparation, discussion until the determination of the budget contained in the Regional Revenue and Expenditure Budget (APBD) which is compiled based on a collection of RKA SKPD, generally the attention of the DPRD is more focused on the size of the budget (Subiyantoro, 2011). The determination of the budget is incremental, the determination of the

budget is influenced by the name of the activity, the determination of the budget is influenced by who submits the budget (Fatikhah R, 2013). This phenomenon is a form of weak budget planning in local governments. Apart from budget problems, organizational performance in the SKPD of the West Sulawesi provincial government is not optimal, it can be seen that the performance in grant management has several procedures in the preparation of the budget for the West Sulawesi provincial government office. , such as the realization of expenditure on goods, budgets and services grants not through the selection of proposals for submitting grants only based on proximity to policy makers or also being the main ideas of members of the board which then the budget is charged to the OPD in terms of employee performance still not being prepared in terms of working time, and also in terms of working hours. budgeting problems, for example determining the name of the activity and the amount of the budget are not fully prepared by the OPD leadership but are prepared by the staff or head of the sub-section who is responsible for the planning section so often in the preparation they do not really consider the amount you want. GIS budget requirements for OPD and budget requirements for employee performance.

Seeing from the above problems in the form of budget allocations that are not in accordance with what they should be, requiring good budget planning in addition, avoiding overlapping expenditure allocations, then arranging each activity logically and compiling a budget based on clear and measurable performance is important. . One of the efforts to achieve this is the development of cost standards (Fadila, 2009). In addition to cost standards, budget evaluation needs to be carried out for the purpose of finding the possibility of a deviation in the budget. Budget evaluation is basically a process of comparing the budget prepared with its implementation, so that from this comparison it can be seen the deviations that occur. The deviations that occur will be used as a basis for measuring efficiency and evaluating performance (Salbiah and Rizky, 2012). So that in this study budget planning and budget evaluation as well as cost standards are linked to see their relationship with improving organizational performance.

There are several previous studies related to this research, including Asmarini's (2013) research which examines the effect of budget planning, cash management and reporting on the performance of SKPD heads, showing that budget planning, reporting and cash management simultaneously affect the performance of SKPD heads. The research of Salbiah and Risky (2012) which tested the effect of budget evaluation on the performance of regional work units (SKPD). The results of hypothesis testing showed that the budget evaluation variable showed a significant influence on the performance variable of the SKPD of the West Sulawesi Provincial Government. The difference from several previous studies is in the variables used and the object of research, in this study budget planning and budget evaluation are used to see their effect on organizational performance by adding cost standards as a moderating variable.

On the basis of the description of the background of the research above, the authors are interested in conducting research with the title: *The Effect of Budget Planning on Organizational Performance Through Cost Standards at the General Bureau of the Regional Secretariat of West Sulawesi Province.*

II. Literature Review:-

Agency theory

Agency theory focuses on two individuals, namely the principal and the agent. The principal delegates responsibility for decision making to the agent. Both principals and agents are assumed to be rational economic people who are motivated solely by self-interest, but they have difficulty distinguishing rewards for preferences, trust and information. The rights and obligations of the principal and agent are described in a mutually beneficial employment agreement. In management accounting research, agency theory is used to identify the combination of employment contracts and information systems that will maximize the principal's benefit function, and behavioral constraints that arise from the agent's interests (Raharjo, 2007).

Agency theory explains the phenomenon that occurs when superiors delegate their authority to subordinates to carry out tasks or authority to make decisions (Anthony and Govindarajan, 1998). Agency relationship in the context of local government between superiors and subordinates, where subordinates carry out the process of planning, implementing and reporting on regional budgets by forming the Regional Government Budget Team (TAPD), while superiors play a role in carrying out supervision (Sundari, 2015).

Goal Setting Theory

The goal setting theory developed by Locke (1968) in Soetrisno (2010) explains the relationship between the goals set and work performance (performance). Based on the Goal-Setting Theory approach, the success of employees in managing the budget is a goal to be achieved by the organization in this case organizational performance, while the variables of budget planning, budget evaluation and cost standards are the determining factors. The higher the determinant, the higher the probability of achieving the goal.

Organizational Performance

Performance is a description of the level of achievement of the implementation of an activity/program/policy in realizing the goals, objectives, mission, and vision of the organization contained in the strategic planning of an organization. Performance as a result of work functions or activities of a person or group in an organization that is influenced by various factors to achieve organizational goals within a certain period of time. Performance is a process of assessing or evaluating work performance in an organization (Putri, 2014). According to Stoner in Salbiah and Risky (2012), performance is the quantity and quality of work completed by individuals, groups, or organizations. In the government sector, performance can be interpreted as an achievement achieved by government employees or government agencies in carrying out services to the community within a period.

Budget Planning

Robbin and Coulter in Latif et al (2014) say that planning is a process that starts from setting organizational goals, namely determining strategies for achieving these goals as a whole to integrate and coordinate all organizational work, so that organizational goals are achieved.

Haryanto, et al (2007) in Asikin (2012) explain that the public sector budget is a periodic financial and activity plan (usually in an annual period) that contains programs and activities and the amount of funds obtained (revenues/income) and required (expenditures/expenditures). in order to achieve organizational goals. Mardiasmo (2009:61) in Wowuruntu (2013) states that "the budget is an estimate of the performance to be achieved during a certain period of time expressed in financial measures", while budgeting is an activity of allocating limited financial resources to finance organizational expenditures that are tends to be unlimited (Haryanto, et al: 2007) in (Asikin, 2012).

Budget Evaluation

In carrying out an activity, evaluation needs to be carried out to find out errors or deficiencies in the process and the final results of the activities that have been carried out, which are useful for making changes or improvements in the next activity (Salbia and Risky, 2012).

Budget evaluation is an action taken to track deviations from the budget by comparing the budget with its realization and used as a basis for performance appraisal. Budget evaluation is an action taken to track the budget of the department concerned and used as a basis for evaluating the performance of the department, in implementing the APBD each SKPD evaluates to assess their respective performance, whether the performance is as planned or vice versa for that a budget must always be evaluated so that later APBD can be implemented as planned. (Aira, 2012).

Cost Standard Analysis

Cost standard analysis is another component that must be developed as a basis for measuring financial performance in the performance budget system, in addition to the Expenditure Standards Analysis (ASB) and performance indicators.

Standard cost is a comparison between spending and performance targets which can also be called the average cost per unit of output. The application of this cost standard helps in preparing the budget for a program or activity for each existing work unit so that the needs for the same activity do not differ in cost. The development of cost standards will be carried out and updated continuously in accordance with changes in prevailing prices, so that budgeting with a performance approach is that the overall process that occurs in government organizations must be measurable, starting from output, outcome/result and impact (Ismail and Idris. 2009:123) in Asikin (2014).

Research Methods:

This study aims to analyze and explain the influence of budget planning on organizational performance through cost standards at the General Bureau of the Regional Secretariat of West Sulawesi Province. The data used in this study is primary data using a questionnaire. This research is a quantitative research, because the research data is in the form of numbers and the analysis uses statistics with the research design of a hypothesis testing study to test the effect between variables. The research uses Path Analysis using the AMOS program. The research sample amounted to 72 respondents. The variables in this study are Budget Planning, Budget Evaluation, Cost Standards and Organizational Performance.

III. Results:-

Description of Research Results

Multiple Linear Regression Analysis Test

By using the AMOS program, the path diagram created is converted to a structural equation, then an analysis is carried out based on the estimated value and probability (significance) of the Budget Planning and Budget Evaluation variables as independent variables followed by Cost Standards as an intervening variable on Organizational Performance at the Regional Secretariat General Bureau West Sulawesi Province. The following table summarizes the path analysis regression weights showing the effect and magnitude of the probability value (significance) of the relationship between variables.

Tabel 4.11
Path Analysis Table

Variable	Estimate	Koefisien Standardized	S.E	C.R	P	Label
Y1□X1	0,510	0,579	0,122	4,191	0,000	par_1
Y1□X2	0,458	0,180	0,109	4,183	0,000	par_2
Y2□X1	0,290	0,037	0,136	2,125	0,034	par_3
Y2□X2	0,414	0,251	0,109	3,800	0,000	par_4
Y2□Y1	0,234	0,219	0,080	2,926	0,003	par_5

Sumber : data primer, diolah AMOS 26

Based on the results of the hypothesis test, the coefficient value of the standardized planning against the Cost Standard is 0.510 and the probability value is 0.000 <0.05. Means that Planning has a positive and significant effect on Standard Costs. Every 1% increase in organizational commitment will result in an increase of 0.510 in Standard Fees.

The standardized coefficient value of Budget Evaluation against Cost Standards is 0.458 and the probability value is 0.000 <0.05, which means that Budget Evaluation has a positive and significant effect on Cost Standards.

The standardized coefficient value of organizational commitment to performance is 0.290 and the probability value is 0.034 > 0.05, which means that planning has a positive and significant effect on performance.

The standardized coefficient value of Budget Evaluation on performance is 0.414 and the probability value is 0.000 <0.05, which means that Budget Evaluation has a positive and significant effect on performance.

The standardized cost coefficient value on performance is 0.234 and the probability value is 0.003 > 0.05, which means that the cost standard has a positive and significant effect on performance.

Tabel 4.12
Estimated Result of Direct and Indirect Effect
(Standardized Coefficient)

Variabel	pengaruh langsung (direct effect)			Pengaruh tidak langsung (Indirect Effect)	
	X2	X1	Y1	X2	X1
Y1	0,180	0,592	0,000	0,000	0,000
Y2	0,251	0,038	0,219	0,039	0,127

Source: primary data, processed by AMOS 26

The standardized coefficient value for planning on performance through Standard Costs is 0.127. This means that planning indirectly has a positive effect on performance through Standard Costs. This indicates that any increase in the quality of planning through the Standard Cost variable will result in an increase in organizational performance.

The standardized coefficient value for Budget Evaluation on performance through Cost Standards is 0.039. This means that indirectly Budget Evaluation has a positive effect on performance through Cost Standards. This indicates that any improvement in the Budget Evaluation through the Standard Cost variable will result in an increase in performance.

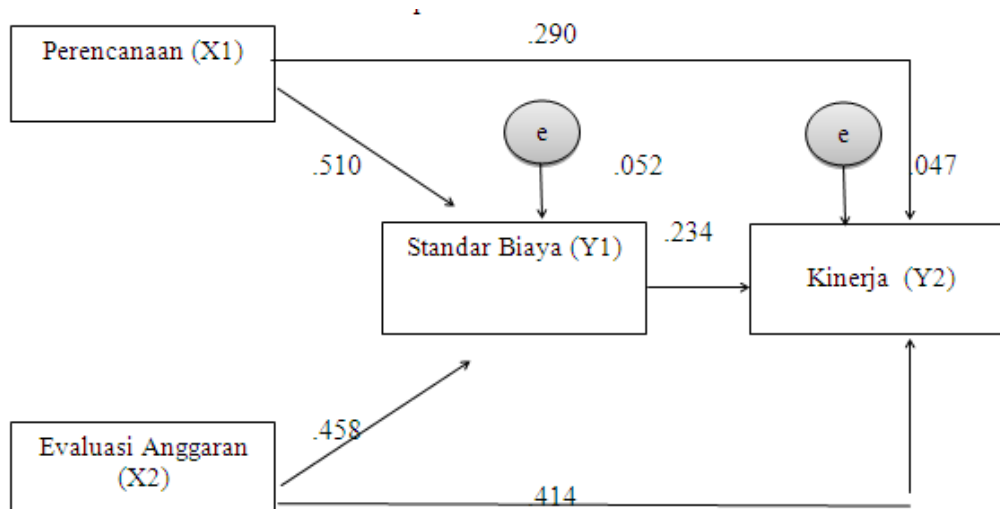

Source: primary data, processed

Figure 4.1 Conceptual Framework and Estimated Results

IV. Discussion:

Analysis of the Direct Effect of Planning on Organizational Performance at the General Bureau of the Regional Secretariat of West Sulawesi Province.

Robbin and Coulter in Latif et al (2014) say that planning is a process that starts from setting organizational goals, namely determining strategies for achieving these goals as a whole to integrate and coordinate all organizational work, so that organizational goals are achieved. Budget planning is a strategic planning subsystem (strategic planning), technically implemented with a performance budget system that is preceded by performance planning. The implementation of the performance budget system in budget preparation begins with the formulation of strategic issues that are responded to with relevant programs and activities. In its implementation, the performance planning process is carried out when translating the Regional Medium Term Development Plan (RPJMD) into the Regional Government Work Plan (RKPD) which is the regional government's annual work plan (Latif et al, 2014).

The results of data processing indicate a positive and significant relationship between budget planning variables on organizational performance. If planning improves, it will encourage an increase in organizational performance at the General Bureau of the Regional Secretariat of West Sulawesi Province.

In line with the goal setting theory or goal setting theory proposed by Locke (1968) explains the relationship between the goals set with work performance (performance). In this study, the intended goal setting is budget planning. Every organization that has set goals that are formulated into a budget plan is easier to achieve its performance targets in accordance with the vision and mission of the organization itself (Kusuma, 2013). This research is also in line with that researched by Neni Herlina (2019) which examines the effect of budget planning on organizational performance. The results of this study indicate a positive and significant influence on the Pangandaran District Civil Service Police Unit.

Analysis of the Effect of Direct Budget Evaluation on Organizational Performance at the General Bureau of the Regional Secretariat of West Sulawesi Province.

Budget evaluation is an action taken to track deviations from the budget by comparing the budget with its realization and used as a basis for performance appraisal. Where if the evaluation carried out is punitive, the motivation will be low, and conversely if the evaluation is supportive it will result in positive behavior and can improve performance. Budget evaluation is an action taken to track the budget of the department concerned and used as a basis for evaluating the performance of the department, in implementing the APBD each SKPD evaluates to assess their respective performance, whether the performance is as planned or vice versa for that a budget must always be evaluated so that later APBD can be implemented as planned. (Aira, 2012).

The results of data processing indicate a positive and significant relationship between budget evaluation variables on organizational performance. If the budget evaluation system in the organization improves, it will encourage an increase in organizational performance at the General Bureau of the Regional Secretariat of West Sulawesi Province. Budget evaluation is basically an assessment tool, comparison, signaling problems, and considering decision making in budget implementation. Budget evaluation is carried out as the basis for evaluating the performance of work units. This study is in accordance with previous research conducted by Supartini Supartini (2020) which examined the relationship between budget evaluation and organizational performance in the Klaten Regency local government. The results of this study indicate that

budget evaluation has a positive and significant impact on organizational performance at the General Bureau of the Regional Secretariat of West Sulawesi Province.

Analysis of Budget Planning on Organizational Performance Through Cost Standards at the General Bureau of the Regional Secretariat of West Sulawesi Province

Budget planning is inseparable from setting cost standards as stated in PMK No.115/PMK. 05 2017 it is stated that the cost standard is the highest limit whose amount cannot be exceeded in the preparation of work plans and budgets of state ministries/agencies for the Fiscal Year. In addition, cost standards can be used as a benchmark for budget evaluation in assessing organizational performance by seeing whether the cost standards that have been set in the budgeting and preparation of activities are not exceeded by the organization (Haslinda, 2016).

The results of the above calculations directly show a positive relationship between the planning variable and the performance variable, which means that if there is an increase in the budget planning system carried out by employees, it will cause an increase in organizational performance at the General Bureau of the Regional Secretariat of West Sulawesi Province and this is in accordance with the hypothesis. . Then. The results of indirect calculations through standard costs as an intervening variable show the standardized coefficient value of 0.127. This means that indirectly budget planning has a positive effect on performance through cost standards. This indicates that any increase in budget planning through standard cost variables will result in an increase in organizational performance at the General Bureau of the Regional Secretariat of West Sulawesi Province.

Standard cost is a comparison between spending and performance targets which can also be called the average cost per unit of output. The application of this cost standard helps in preparing the budget for a program or activity for each existing work unit so that the needs for the same activity do not differ in cost. The development of cost standards will be carried out and updated continuously in accordance with changes in prevailing prices, so that budgeting with a performance approach is that the overall process that occurs in government organizations must be measurable, starting from output, outcome/result and impact (Ismail and Idris. 2009:123) in Asikin (2014). This research is supported by Basiem Al-Shattarat (2021) who examines the impact of standard costs on the performance of industrial companies in Jordan. The results show that there is a positive relationship between standard costs and the performance of industrial companies in Jordan. So the researcher concludes that there is an influence between budget planning on performance through cost standards.

Budget Evaluation Analysis of Organizational Performance Through Cost Standards at the General Bureau of the Regional Secretariat of West Sulawesi Province.

Based on the theoretical basis above, a framework of thought can be formulated that budget planning and budget evaluation can be a trigger for increasing organizational (local government) performance. According to Fadila (2009) stated that the cost standard is something that needs to be considered in arranging activities logically and preparing a budget based on clear and measurable performance. So in this study the cost standard is used as a moderator between budget planning and budget evaluation in relation to organizational performance (local government).

The results of the above calculations directly show a positive relationship between the budget evaluation variable and the performance variable, which means that if budget evaluations are often held or improvements to the budget evaluation system are carried out, it will cause an increase in organizational performance at the General Bureau of the Regional Secretariat of West Sulawesi Province and this is in accordance with hypothesis. Then. The results of indirect calculations through standard costs as an intervening variable show the standardized coefficient value of 0.039. This means that indirectly budget evaluation has a positive effect on performance through cost standards. This indicates that any increase in budget evaluation through standard cost variables will result in an increase in organizational performance at the General Bureau of the Regional Secretariat of West Sulawesi Province.

Based on the provisions of article 24 paragraph (1) PMK No.71/PMK.02/2013 concerning Guidelines for Cost Standards, Cost Structure Standards, and Indexation in the Preparation of K/L RKA, the Ministry of Finance and/or K/L is mandated to carry out monitoring and evaluation (Monev) implementation of standard output costs (SBK) in accordance with their authority. Until now, both in the implementation of the duties of the cost standard policy and budgeting monev, no monev has been carried out with regard to the cost standard, which in this case is the SBK. On the other hand, there is currently no regulation that stipulates or explains in more detail what aspects need to be monitored.

V. Conclusion:

Based on the results of the research and discussion above, it can be concluded:

1. The results of the analysis of budget planning research have a positive and significant effect on

organizational performance, this proves that whether or not planning is good can affect organizational performance at the General Bureau of the Regional Secretariat of West Sulawesi Province.

2. The results of the analysis of budget evaluation research have a positive and significant effect on organizational performance, this proves that whether or not the evaluation carried out by the organization can affect organizational performance at the General Bureau of the Regional Secretariat of West Sulawesi Province.

3. The results of the analysis of budget planning research have a positive and significant effect on organizational performance through cost standards. This indicates that any increase in budget planning through standard cost variables will result in an increase in organizational performance at the General Bureau of the Regional Secretariat of West Sulawesi Province.

4. The results of the analysis of budget evaluation research have a positive and significant effect on organizational performance through cost standards. This indicates that any increase in budget evaluation through standard cost variables will result in an increase in organizational performance at the General Bureau of the Regional Secretariat of West Sulawesi Province.

BIBLIOGRAPHY

- [1]. Adrianto, Yogi. 2008. "Analysis of the Influence of Participation in Budgeting on Managerial Performance with Job Satisfaction, Job Relevant Information and Job Satisfaction as Moderating Variables", Diponegoro University, Semarang.
- [2]. Aira, Aras. 2012. The Effect of Clarity on Budget Targets and Budget Evaluation on Budget Monitoring (Empirical Study in Kampar Regency). Journal, Vol. 3, No. 1, p. 39 – 47
- [3]. Anggraeni, raika. 2009. The Effect of Budget Participation and Organizational Commitment on the Performance of the Labuhan Batu Regency Government SKPD. Essay. Faculty of Economics and Business – University of North Sumatra. Medan.
- [4]. Arianty, Nel. 2014. The Influence of Organizational Culture on Employee Performance. Journal of Management and Business, Vol. 14, No. 2, p. 145-150.
- [5]. Arikunto, Suharsimi. 2002. Research Methodology. Publisher PT. Rineka Cipta. Jakarta.
- [6]. Anthony, Robert N., and Govindarajan, 1998. Management Control System, Ninth Edition. New Jersey: McGraw Hill. Translated by F.X. Kurniawan Tjakrawala, in Management Control Systems, Jakarta: Salemba Empat.
- [7]. Asikin, Decky Firmansyah. 2012. Factors Influencing Performance-Based Budgeting (Empirical Study on Makassar City Government, South Sulawesi Province). Essay. Faculty of Economics and Business – Hasanuddin University. Makassar.
- [8]. Asmarani, Tias. 2013. The Effect of Budget Planning, Cash Management and Reporting, on the Performance of SKPD Heads (Case Study on Pematang Siantar City Government). Thesis. Faculty of Economics and Business – University of North Sumatra. Medan.
- [9]. Atmaja, Teguh Eko et al. 2016. Analysis of Education Cost Standard Setting at Sma Negeri 2 Kuala Nagan Raya Regency. Journal of Postgraduate Education Administration at Syiah Kuala University, Volume 4, No. 1, p. 119-128.
- [10]. Basri.2013. Analysis of Budgeting and Budget Realization Reports at BPM-PD of North Sulawesi Province. *Emba's Journal*, Vol. 1, No. 4, p. 202-212.
- [11]. Darmawati.2019. The Role of Accounting Information in the Government Sector: Agency theory perspective. *Economics Bosowa Journal*. Volume 5, No. 001
- [12]. DuBrin, A. J. (2012). *Essentials of management*. Mason, OH: Cengage South West.
- [13]. Fadilah, Sri. 2009. Activity Based Costing (ABC) as a New Approach to Calculating the Analysis of Expenditure Standards (ASB) in the Preparation of the Regional Revenue and Expenditure Budget (APBD). *Journal of Accounting Studies & Research* Vol. 2. No. 1, p. 54-78.
- [14]. Fatikhah R, Dewi Noor. 2013. Analysis of Batu City Government Expenditure Standards Analysis. *FEB Student Scientific Journal*, Vol. 1, No. 2, Pg. 1-15.
- [15]. Iskandar, Dudi. 2013. The Influence of Human Resource Capacity, Planning and Budgeting Politics, with Public Transparency as a Moderating Variable on APBD Documents with KUA-PPAS Documents on Southeast Aceh District Government. *Journal of Accounting Studies and Research* Vol. 6, No.1.
- [16]. Kadek Suyadnya, et al, 2014, Analysis of planning and budget realization and evaluation of company performance UD. Agus Kusuma. *FEB Student Scientific Journal – Ganesha Singaraja University of Education*. Indonesia. Vol 4 No 1
- [17]. Kerlinger. Fred N. 2004. "Principles of Behavioral Research". Yogyakarta: Gadjahmada University,
- [18]. Kurniawan, Chandra. 2012. Analysis of the Effect of Performance-Based Budgeting on Regional Financial Performance in Metro City. Essay. Faculty of Economics and Business- Lampung University. Bandar Lampung.
- [19]. Kusuma, I Gede Eka Arya. 2013. The Effect of Clarity on Budget Targets, Organizational Commitment and Environmental Uncertainty on Budget Accuracy (Empirical Study in SKPD of the Provincial Government of Bali). Thesis. Faculty of Economics – Udayana University. Denpasar.
- [20]. Daughter, Ana Suseno. 2014. The Influence of Organizational Commitment, Leadership Style, and Job Satisfaction on the Performance of Public Organizations (Empirical Study on the Boyolali District Government SKPD). Publication Text. Faculty of Economics and Business- Muhammadiyah University. Surakarta.
- [21]. Raharjo, Eko. 2007. Agency Theory and Stewardship Theory in Accounting Perspective. *Economic Focus*, Vol. 2, No. 1, Pages: 37-46.
- [22]. Rosmawati. 2011. The Effect of Budget Planning and Supervision on Managerial Performance in North Aceh District SKPD with Budget Participation as a Moderating Variable. Thesis. Faculty of Economics and Business – University of North Sumatra. Medan.
- [23]. Latif, Muh et al. 2014. Planning of the Social Assistance Budget in the Regional Revenue and Expenditure Budget. *Discourse–* Vol. 17, No. 2, p. 78-87.
- [24]. Locke, E. A. and Latham, G. P. 1990. *A Theory of Goal Setting and Task Performance*. Englewood Cliffs, NJ: Prentice-Hall.
- [25]. Noviawati, Ika. 2014. The Effect of Locus Of Control, Distributive Justice, Procedural Justice and Trust on Budgetary Slack. *Economic & Business Research Festival* pp. 1681-1697.
- [26]. Singarimbun, Masri and Sofian Effendi, *Survey Research Methods*, Jakarta: LP3ES, 2006.
- [27]. PMK No. 249 of 2011 concerning Performance Measurement and Evaluation of the Implementation of Work Plans and Budgets of State Ministries/Agencies.
- [28]. PMK Number 115/PMK.02/2015 – Standard Output Costs for Fiscal Year 2016

- [29]. Salbiah and Rizky, Rida. 2012. The Effect of Budget Evaluation on the Performance of Regional Apparatus Work Units (SKPD) of the North Sumatra Provincial Government. *Journal of Economists*, Vol 15, No 2, p. 42-52.
- [30]. Sugiyono, (2013). *Qualitative Research Methods and R&D*. Bandung Alfabeta.
- [31]. hard. 2003. *Competency Education Research Methodology and Practice*. Jakarta: Earth Literacy.
- [32]. Siregar, Syofian. 2014. *The quantitative research method is equipped with a comparison of manual calculations and SPSS*. Jakarta: Kencana.
- [33]. Soetrisno .2010. *The Effect of Participation, Motivation and Delegation of Authority in Budgeting on Managerial Performance*. Thesis. Faculty of Economics - Diponegoro University. Semarang.
- [34]. Sumadi Suryabrata. 2003. *Research Methods*. Jakarta: Rajawali.
- [35]. Tamasoleng, Adelstin. 2015. Analysis of the Effectiveness of Budget Management in the Regency of the Siau Islands, Tagulandang Biaro. *Journal of Business and Management Research* Vol.3, No.1, p. 97-110.
- [36]. Tuasikal, Askam. 2011. Phenomenology of Regional Government Planning and Budgeting. *Journal of Accounting*, University of Jember. pp 78-91.
- [37]. Verasvera, Febrina Astria. 2016. *The Effect of Performance-Based Budgeting on the Performance of Local Government Apparatuses (Case Study at the Social Service Office of West Java Province)*. *Journal of Management*, Vol. 2, No. 2, p. 137-162.
- [38]. Waworuntu, Tika Sari Sandra. 2013. Evaluation of Budgeting as a Management Control tool for BLU RSUP Prof.dr. R.d. Kandou Manado. *EMBA Journal* Vol.1 No.3, p. 904 – 913.
- [39]. Widodo. 2015. *Regional Planning and Budgeting Module*. Jakarta.
- [40]. <https://www.abacademies.org/articles/the-impact-of-the-standard-costing-system-on-the-performance-of-industrial-companies-in-jordan-10114.html>