



Research Paper

Design and Development of a Double Screening novel Rice Destoning Machine

Nwosu A. W. and Obinwa C. C

National Engineering Design Development Institute (NEDDI), Nnewi, National Agency for Science and Engineering Infrastructure (NASENI), the Presidency, Abuja, Nigeria.

Corresponding Author: arinzenwosu2022@gmail.com

Abstract: Locally processed rice grains are not attractive to most rice consumers in Nigeria. This is because of the high extraneous materials contained in the stock. It is accorded out-right rejection, low demand and low pricing compared to imported rice. Nigerians crave for the cleaner debris-free foreign rice thereby siphoning monies to other countries. Though Nigeria has banned importation of foreign rice, people continue to bring the commodity through illegal means. The conventional type rice grains de-stoning machines which are fed in batches apart from the shortcoming of lower separation efficiency, cannot satisfy the commercial demand for stone-free rice grains. The need for a more efficient machine with capacity for commercial processing is imperative if the produced in Nigeria rice shall be found of good quality and globally competitive. This novel equipment permits continuous feeding in a controlled manner and exposes all materials fed into the screening tray to the screening areas. The machine engenders higher separation efficiency as the rice grains are completely free from stones and solid impurities while processing capacity has been greatly enhanced. The key feature of the innovation is a slider powered by an electric motor driven pulley and controlled by a manually operated lever to set the quantity of rice grains continuously discharging into the screening area. Separation of rice grains and extraneous materials are performed in two phases which attends to all sizes of the solid impurities, collecting only stone-less rice grains at the second screening tray discharge. The rice quality compares favourably with imported commodity. It is hoped that the proliferation of this equipment and deployment for rice de-stoning shall assuredly enhance good quality local rice production thereby dissuade our people from the huge patronage hitherto given to foreign rice.

Keywords: Rice, Stone, Separation, Quality, Machine

Received 08 July, 2022; Revised 21 July, 2022; Accepted 23 July, 2022 © The author(s) 2022.
Published with open access at www.questjournals.org

I. INTRODUCTION

Rice is the most economically important food crop in many developing countries and has also become a major crop in many developed countries where its consumption has increased considerably. It has become necessary to meet the demand of the world's current population growth rate, and the least costly means for achieving this aim is to increase rice productivity, wherever possible. (Ajala and Gana, 2015).

Agriculture remains an important sector of the nation's economy. Its products have always been a major sustenance of life and rice is not an exception. Rice is cultivated in almost all parts of the globe including Nigeria. Rice is now the staple food of 2.7 billion people, almost half the world's population, and is grown by more than half the world's farmers. The enormous productivity of intensified paddy rice systems accounts for the very high population densities and rich cultures that have developed alongside the major river systems of Asia (Fairhurst and Dobermann, 2002). Rice culture is thus the cornerstone of cultural, social, and economic development in Asia. Rice is one of the staple foods in Nigeria and it is cherished by almost all the ethnic groups and it is prepared into various delicacies. For instance, in the northern part of Nigeria, rice can be milled and used for flour and also molded and fried into cakes. Large acres of rice plantation can be found in these areas; Lafia (Northern Nigeria), Benue state (Middle Belt), Osun state (Western Nigeria), Abakaliki (eastern Nigeria) and several other places.

Rice is a staple food crop which is cultivated and eaten in most part of the world. Saka and Lawal (2009) classified rice as the most important food depended upon by over 50 percent of the World population for about 80 percent of their food need. However, only 1.9 million hectares representing about 40 percent out 4.6 –

4.9 million hectares of Nigeria's total cultivable land mass is cropped with rice (Ohwofadjeke and Ogheneochuko, 2020). Due to the growing importance of the crop, Food and Agricultural Organization (FAO, 2001) estimated that annual rice production should be increased from 586 million metric tons in 2001 to meet the projected global demand of about 756 million metric tonnes by 2030.

Research has shown that production and processing technologies have not been able to meet the increasing demand for rice (FAO, 2001). In the West African sub region, Nigeria has experienced a well-established growing demand for rice caused by rising per capita consumption and consequently the insufficient domestic production had to be complemented with enormous import both in quantity and value at various times (Saka and Lawal, 2009).

In Nigeria, rice consumption has risen tremendously at about 10% per annum due to changing consumer preferences (Akande, 2003). However, Ebuehi and Oyewole (2007) discovered that most Nigerians prefer to consume imported rice brands as compared to local rice varieties. The reason is that most Nigerian rice processors lack adequate technology of rice processing to meet international standard.

Rice processing involves several steps: cooking and steaming the harvested rice, removal of the husks, milling the shelled rice to remove the bran layer, destoning to remove stones and an additional whitening or polishing step to meet market expectations for appearance of the rice kernels. This process generates several streams of material which include the husks, the bran, and the milled rice kernel (Schramm, 2006). The conventional rice destoning machine shown in Plate 1 and 2 use a single screening chamber and batch operation. The technology employed is an undersigned system. Its system of operation has a low efficient in screening of rice grains containing solid impurities and has a continuous clogging when fully fed since there are no mechanism to regulate the flow of rice grains going in for screening.



Plate 1: Conventional Rice Destoner machine



Plate 2: Conventional Rice Destoner machine

Physical analysis of rice dimensions of several rice species was conducted by Kruszelnicka *et al.*, (2020). The graphical representation (Figure 1) of grain volume determination based on the knowledge of three dimensions, a_1 —length of the grain, mm, a_2 —width of the grain, mm, a_3 —height of the grain, mm, vs.—grain volume calculated based on three dimensions a_1 , a_2 , a_3 (volume of a cuboid with dimensions a_1 , a_2 , a_3), mm^3 , V_p —grain volume calculated based on the volumetric mass density, mm^3 . The analysis shows that the average grain length of rice is 6.38 mm, average width is 1.91 mm, average height is 1.51 mm, average grain volume is equal to 14.82 mm^3 , while the average volume of grain is 18.44 mm^3 . Similar and less dimensions are obtained in stones and other debris. Thus some stones and other solid impurities scale through the pneumatic system during pneumatic cleaning operations. This is because they have same or less weight compared with the rice grains. Although, different in size and shape but exhibiting similar gravitational behavior. Meanwhile, flooding of the screening tray also reduces and alters screening efficiency during operation. It can be inferred that a more efficient separation system would require double check on second platform as well regulated feeding of material to ensure total flushing out of impurities.

In the place of a single screening layer and flooding the screening tray with a shorter travel time, this innovation employs a screening tray to collect stones and solid impurities larger than the rice grains; a second tray to collect stones and solid impurities smaller than the rice grains; a slider plate powered by a pulley driven mechanism to provide opening for rice grains in the hopper to be discharged into the screening process, and a manually controlled Lever to determine the quantity of rice grains discharging from the hopper into the first screening tray. This work presents the novel equipment which is capable of destoning the entire rice grains. For the clogging and choking, the invention provides a mechanism that regulates feeding. The regulated feeding matches the pneumatic pressure to weight of grains and as such enables the grains going into the screening tray to pass through without resting the entire weight on the tray. These were attained by laboratory tests and analysis.

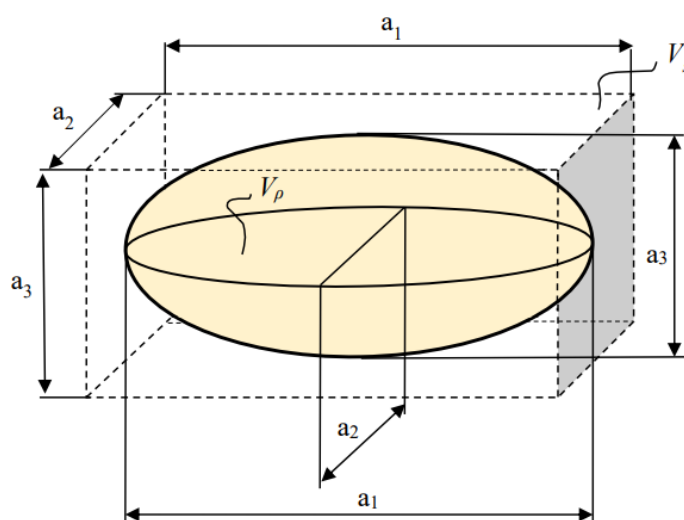

Figure 1: Graphical Representation of Rice grain
(Source: Kruszelnicka *et al.*, 2020).

II. AIM AND OBJECTIVE

Rice cultivation in Nigeria is faced with the problem of de-stoning which has made rice produced in Nigeria undesirable by Nigerians. Hence, many have resorted to consuming imported rice. Only few farmers have been able to maneuver this problem by using imported rice de-stoners. The need to improve the quality of rice, increase production, maximize time and reduce human labour involved has brought about the development of this novel rice de-stoner. Introduction of an efficient and cost effective de-stoner appears as the only option left for the present day rice farmers in Nigeria to thrive. The aim of this work is to develop a separation efficient rice destoning machine from locally available materials that would render locally produced rice to be free of stones thereby promote the production of stone free rice in commercial quantities while enhancing its appeal to consumers.

III. METHODOLOGY

The methodology entailed the following processes:

- i. Visitation of rice processing clusters to ascertain different varieties of rice and the destoning processes.
- ii. Questionnaires distribution to rice farmers and marketers to get avail information on prevailing rice destining methods, market appeal and prevailing conditions in the sector.
- iii. Concept development based on information analysis outcome and projection
- iv. Design and engineering drawing production.
- v. Prototyping the machine.
- vi. Test and evaluation of the developed machine.

IV. MACHINE DESCRIPTION

The complete setup of the entire rice destoning machine is shown in Figure 2, revealing the two Screening Trays (4) in Figure 3 in an isometric view. The feeding controlling mechanism is well covered to prevent the operator being exposed to potential accidents during operation. The novel rice destoning machine consist of Hopper (3), Collector Tray (1), Screen Trays (4), Electric motor(22), Feed Control Lever (30), Discharge Channel (2), Split Discharge (6), Slider (17), Slider Lever (20), Slider Connecting Rod 2 (21) Slider Push Rod 1 (18), Push Rod 1 (13), Connecting Rod 1 (15), Control Push Rod 1 (29), Quantity Control Sliding Rail (28), Pulley (12), V-Belt (10), Feed Quantity Control (19) and the Stand (5).

As shown in Figure 3, the Stand (5) is a connection of angle irons (50 x 50 x 4 mm) welded together to provide a firm support for mounting all the parts and components together. An Electric Motor (22) of 1Hp powered by 220V of electrical energy serves as the prime mover. The Hopper (3) holds a volume of 0.22 m³ of rice grains.

Then the Slider(17) continuously opens and closes when the Electric Motor is actuated. But the time interval for discharging rice grains when it opens is determined by the speed of the Electric Motor used in conjunction with the level of set by the Feed Control Lever (30). The quantity of the rice grains to be discharged is being regulated by the Feed Control Lever being linked to the Slider by the Control Push Rod 1 (29), Feed Quantity Control (19) and Slider Lever (2) as shown in Figure 5 and 6. The Feed Quantity Controller slides on the Quantity Control Sliding Rail (28) which provides the pivot base for the Slider Lever so as to adjust the start and end movement of the Slider (17). The movement of the Slider achieved through linear conversion of circular motion from a motor driven Pulley (12), connected to the Slider via the Slider Connecting Rod 2 (21), the Slider Lever (20) which serves as a tappet and Slider Push Rod (18). This provides a well monitored feeding system as the rice grains enter the Screen Trays. Rice grains discharged when the slider opens, passes through the Split Discharge (6) channel, sharing the rice grains in two paths in order to have the grains widely spread across the first Screen tray. This helps to expose every material discharged to the face of the Screen Tray before entering the Discharge Channel (2) as waste from the first separation process.

The top and bottom Screen Trays (4) are connected to a fixed pivoted Push Rod 1 (13). The Push Rod 1 alternatively pushes the Screen Trays back and front continuously when the Electric Motor is actuated, causing the Screen Trays to vibrate during operation. The circular motion is also converted to linear motion for the Screen Trays to utilize through the Oscillating Wheel (14) causing a damping effect which is transferred to the Connecting Rod 1 (15) that pull and pushes the Push Rod 1.

Rice grains escape the top Screen Tray leaving behind larger extraneous material on the Screen Tray to be discharged as waste at the Discharge Channel. The escaped rice grains are collected below the first Screen Tray by the Collector Tray, which redirects the rice grains to the bottom Screen Tray. The collector discharges the rice grains and smaller extraneous materials on the top side of the bottom Screen Tray so that all the rice gains and the extraneous materials can slide down the Screen Tray to effectively separate the extraneous materials from the rice grains. Meanwhile, only smaller extraneous materials escape the bottom Screen Tray and leaving behind the rice grains. Thus, a stone free rice grains are collected at the discharge of the bottom Screen Tray Discharge Channel. The smaller extraneous materials are collected by the Collector Tray placed directly under the bottom Screen Tray. The smaller extraneous materials are also discharged as waste at the Stone Discharge Channel (31), in order to avoid hiping of the extraneous materials directly under the bottom Screen Tray.

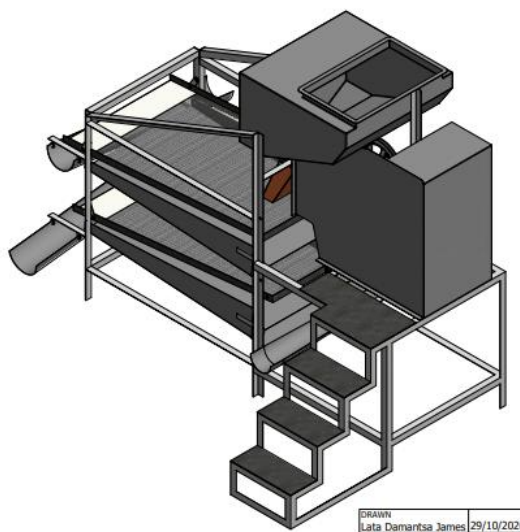

Figure 2: Isometric View of the Rice Destoning Machine

In Figure 3, the Orthographic drawing of the rice destoning machine is presented, revealing the space the machine occupies. The machine has the total size of 2.5 x 1.6 x 2 m (L x W x H). Figure 4, shows the Exploded view of the rice destoning machine. Presenting all the parts/components and linkage between all operating systems. In the Figure 5 and 6, the feeding mechanism and separation system are presented. This depicts how the Slider (17) in Figure 5 is being controlled by the Pulley (12) to allow the rice grains from the Hopper flow within intervals.

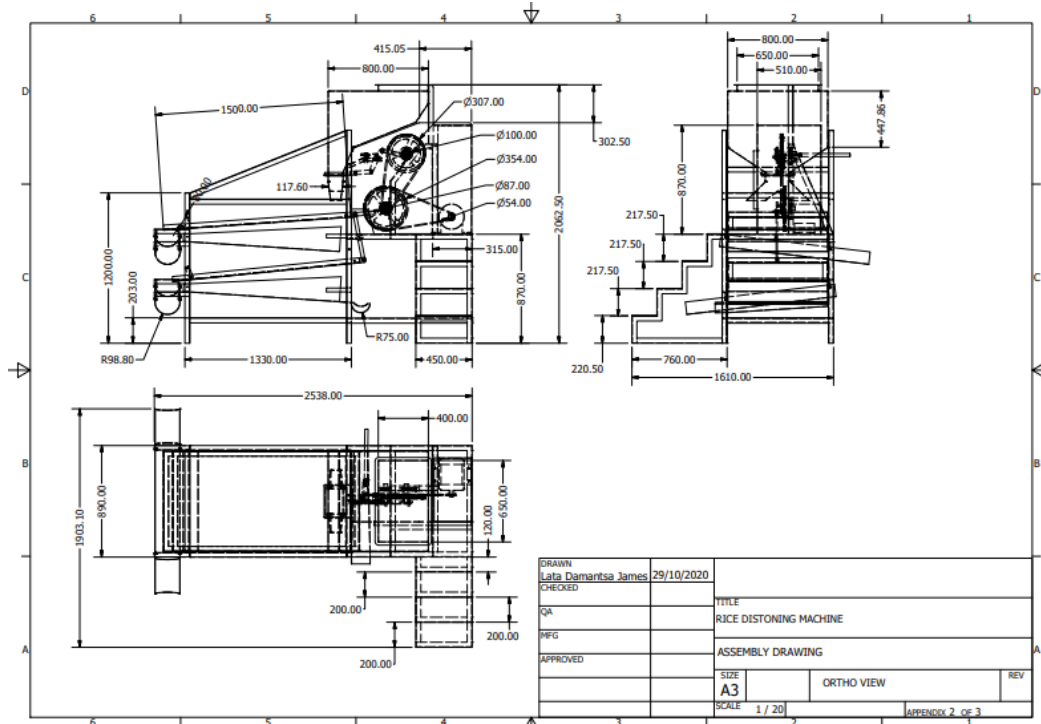

Figure 3: Orthographic View of the Rice Destoning Machine

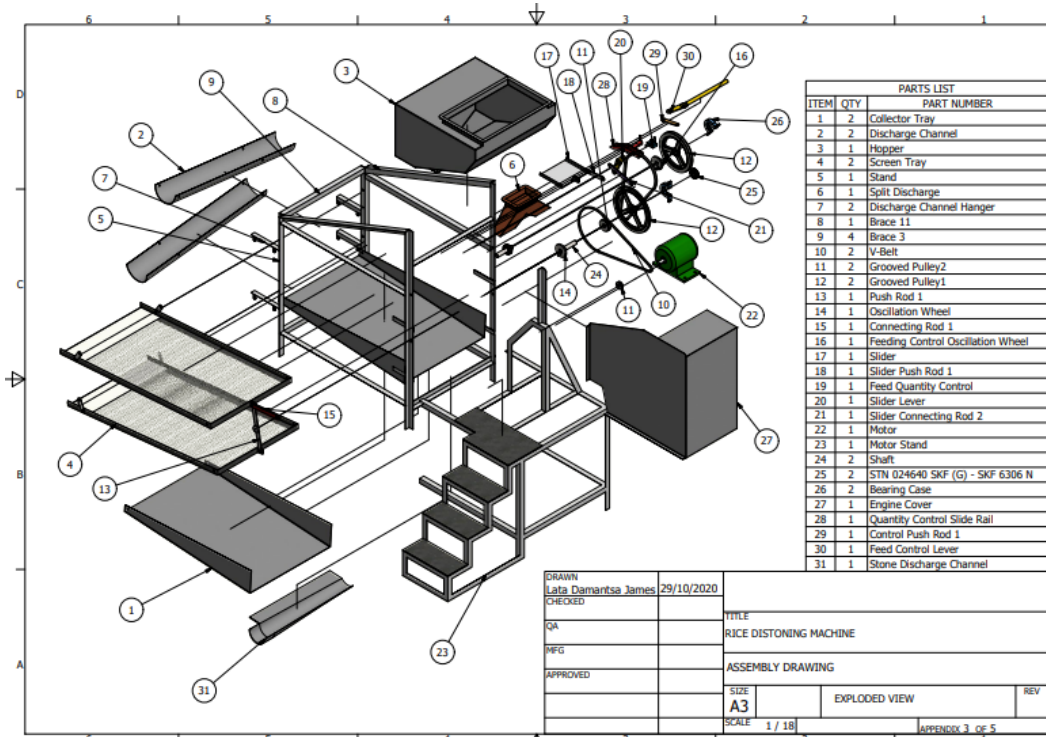

Figure 4: Exploded View of the Rice Destoning Machine

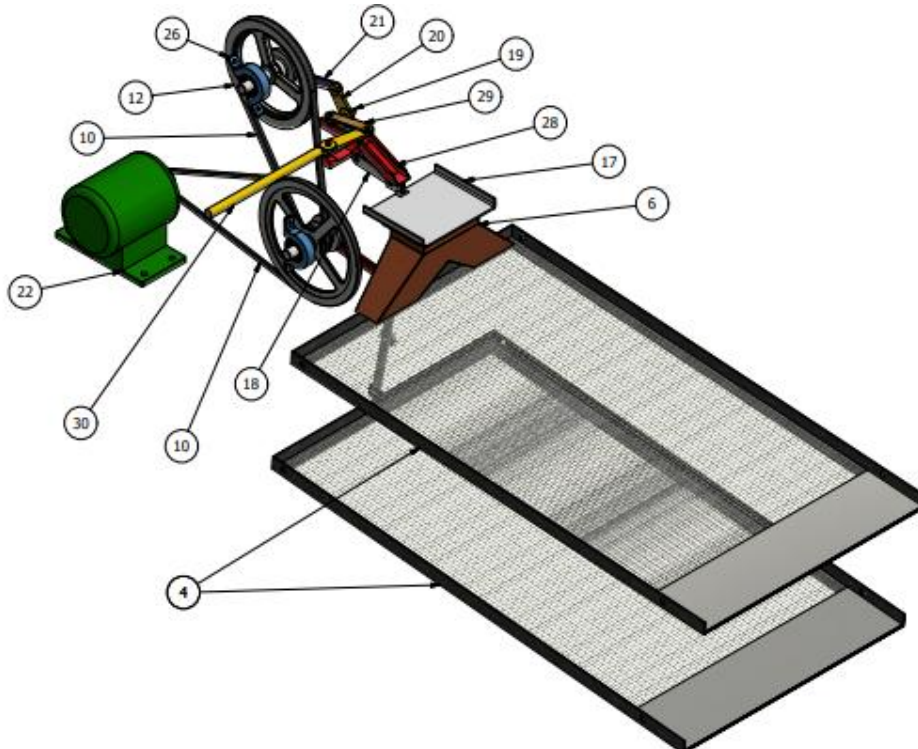

Figure 5: Isometric View of the Feeding Mechanism and Separation System

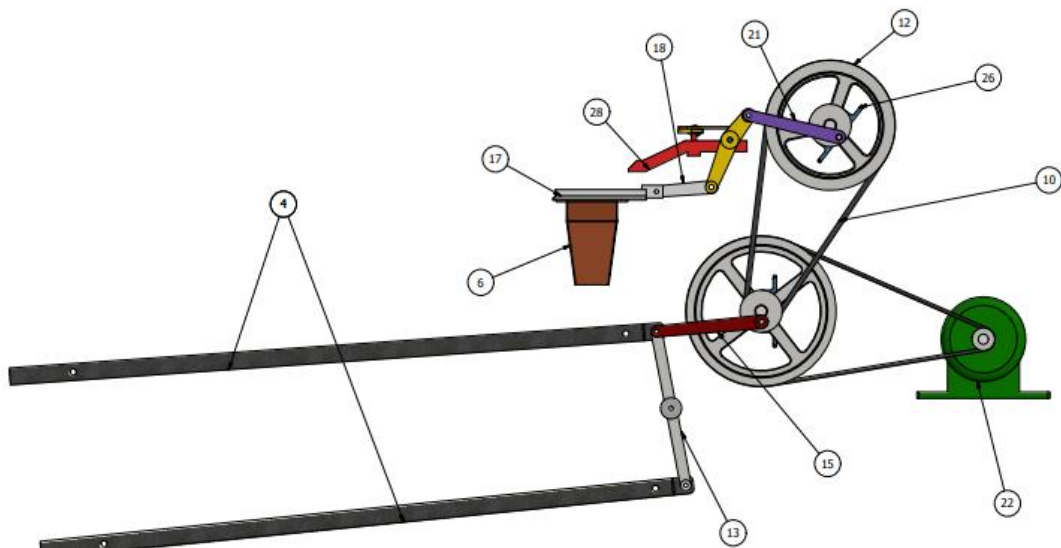

Figure 6: Side View of Feeding Mechanism and Separation System

IV. RESULTS

The Double Screen novel Rice destoning machine is shown in Plate 3. The machine can effectively separate rice from stones based on their physical properties which are basically on the size differences. The machine is designed with two sieves of different meshes and vibration is powered by a 0.50 kW and rotational speed of 700 rpm DC electric motor. The de-stoner has the efficiency of 80% and mass flow rate of 2.10 kg/s which is equivalent to 7.50 t/hr capacity.



Plate 3: Double Screen novel Rice Destoning Machine

V. CONCLUSION

An improved rice destoning machine was designed and constructed by research engineers of the National Engineering Design Development Institute (NEDDI), Nnewi, National Agency for Science and Engineering Infrastructure (NASeni), the Presidency, Abuja, Nigeria. The performance evaluation shows that though the double screens improved its performance above conventional single screen destoners, its efficiency is reduced when the rice-stone mixture are about the same size. The study recommends incorporation of massive pneumatic flow to lift the rice off all stones based on relative differential buoyancy. Efficiency was improved at low quantities and low feed rates.

REFERENCES

- [1]. Ajala A, S. and A. Gana A. (2015). Analysis of Challenges Facing Rice Processing in Nigeria. Journal of Food Processing, Volume 2015, p. 1.
- [2]. AkandeT. (2003). The Rice Sector in Nigeria, United Nation Crop Project (UNCP) Country Agricultural Project on Trade Liberalization in Agricultural Sector and the Environment, Geneva, Switzerland.
- [3]. EbeuhiO. A. T. and OyewoleA. C. (2007). "Effect of cooking and soaking on physical characteristics, nutrient composition and sensory evaluation of indigenous and foreign rice varieties in Nigeria," African Journal of Biotechnology, vol. 6, no. 8, pp. 1016–1020.
- [4]. F.A.O. (2001) "Farming systems and poverty: improving farmers' livelihoods in a change world", Rome: Food and agricultural organization.
- [5]. Kruszelnicka, W., Andrzej M., Robert K., Patrycja B., Katarzyna P., Józef F., and Andrzej T.. (2020). "Mechanical and Processing Properties of Rice Grains" Sustainability 12, no. 2: 552. <https://doi.org/10.3390/su12020552>

- [6]. Ohwofadjeke, P. and Oghenechuko (2020). Development of Low Cost Rice De-Stoning Machine. Int. J. of Eng. and App. Sci. (IJEAS)ISSN: 2394-3661, Vol-7, Iss-1.
- [7]. SakaJ. O., and Lawal B. O. (2009), "Determinants of adoption and productivity of improved rice varieties in south western Nigeria", African Journal of Biotechnology. Vol. 8 (19), pp. 4923 – 4932.
- [8]. Schramm, R. C. (2006). "Rice processing: milling and value-added effects". LSU Master's Theses.https://digitalcommons.lsu.edu/gradschool_theses/887, Vol. 16, p. 2.